

THE APOLLO INTELLIGENT METER SERIES



MODEL IMY INSTRUCTION MANUAL

INTRODUCTION

The Intelligent Meter for Thermistor Inputs (IMY) is another unit in our multi-purpose series of industrial control products that are field-programmable to solve multiple applications. This series of products is built around the concept that the end user has the capability to program different personalities and functions into the unit in order to adapt to different indication and control requirements.

The Intelligent Thermistor Meter which you have purchased has the same high quality workmanship and advanced technological capabilities that have made Red Lion Controls the leader in today's industrial market.

Red Lion Controls has a complete line of industrial indication and control equipment, and we look forward to being of service to you now and in the future.



CAUTION: Read complete instructions prior to installation and operation of the unit.



CAUTION: Risk of electric shock.

Table of Contents

SAFETY INFORMATION	3
Safety Summary	3
GENERAL DESCRIPTION	4
Theory Of Operation	4
Block Diagram	5
PROGRAMMING AND OPERATING THE IMY	6
Programming the IMY	6
Module #1 - Program Thermistor Type, Temperature Scale (F or C) and Decimal Point Position	8
Module #2 - Program Temperature Display Offset and Slope	8
Module #3 - Program Functions Accessible W/ Front Panel Lockout	9
Module #4 - Program Digital Filter and Remote Input	11
Module #5 - Program Integrator/Totalizer	13
Module #6 - Program Alarm/Setpoint	14
Module #7 - Program Serial Communications	16
Module #8 - Program Re-Transmitted Analog Output	17
Module #9 - Service Operations	18
Operating The IMY	19
Quick Programming	19
Factory Configuration	20
Temperature Monitoring Example	22
INTEGRATOR / TOTALIZER / PEAK / VALLEY / TEMPERATURE OFFSET (Optional)	23
Integrator/Totalizer	23
Peak/Valley	23
Offset And Slope Display Temperature	23
Integrator/Totalizer Example	24
Integrator/Totalizer Set-Up	24
ALARMS (Optional)	26
20 mA CURRENT LOOP SERIAL COMMUNICATIONS (Optional)	27
General Description	27
Communication Format	27
Sending Commands to the IMY	28

Command String Examples	28
Receiving Data from the IMY	30
Current Loop Installation	30
Serial Terminal Descriptions	30
Serial Communications Examples	31
RE-TRANSMITTED ANALOG OUTPUT (Optional)	33
Analog Output Calibration	34
APPENDIX "A" - INSTALLATION & CONNECTIONS	35
Installation Environment	35
Panel Installation	35
Select AC Power (115/230 VAC)	35
EMC Installation Guidelines	36
Wiring Connections	37
Power Wiring	37
Signal Wiring (Thermistor)	37
User Input Wiring	37
Output Wiring	37
APPENDIX "B" - SPECIFICATIONS AND DIMENSIONS	38
APPENDIX "C" - TROUBLESHOOTING GUIDE	41
APPENDIX "D" - PROGRAMMABLE FUNCTIONS	42
APPENDIX "E" - ORDERING INFORMATION	44

SAFETY INFORMATION

SAFETY SUMMARY

All safety related regulations, local codes and instructions that appear in the manual or on equipment must be observed to ensure personal safety and to prevent damage to either the instrument or equipment connected to it. If equipment is used in a manner not specified by the manufacturer, the protection provided by the equipment may be impaired.

Do not use this unit to directly command motors, valves, or other actuators not equipped with safeguards. To do so, can be potentially harmful to persons or equipment in the event of a fault to the unit.

DEFINITION OF TERMS

INSTALLATION CATEGORY (overvoltage category) I:

Signal level, special equipment or parts of equipment, telecommunication, electronic, etc. with smaller transient overvoltages than Installation Category (overvoltage category) II.

INSTALLATION CATEGORY (overvoltage category) II:

Local level, appliances, portable equipment, etc. with smaller transient overvoltages than Installation Category (overvoltage category) III.

GENERAL DESCRIPTION

The Apollo Intelligent Thermistor Meter (IMY) accepts standard Thermistor inputs and precisely linearizes them into temperature readings. Like an RTD, a thermistor is a temperature sensitive resistor, but the thermistor provides a much larger resistance change per degree. Since thermistors provide a large resistance change, significant errors from long lead lengths or switches are eliminated. Other advantages of using a thermistor are accuracy, repeatability, long term stability, and sensor cost. A full 6-digit display accommodates a wide range of temperature inputs and holds large totalization values. State-of-the-art digital circuitry virtually eliminates errors due to drift. A full complement of option packages is available to fulfill many process applications.

The IMY supports two popular thermistor series - the 400 Series 2,252 Ohm thermistor, and the 700 Series Thermoliner™ thermistor. Selection between the two types is done in Programming Module #1.

The indicator features a readout choice of either Fahrenheit or Celsius with 0.1 or 1 degree of resolution. English Style display prompts aid the operator through set-up and operation. A front panel lock-out menu protects set-up data and operation modes from unauthorized personnel. Programmable digital filtering enhances the stability of the reading. Programmable remote input "E1-CON" pin can be utilized to control a variety of functions, such as totalizing, alarm control, peak/valley reading, display hold or offset operations. All set-up data is stored in the E²PROM, which will hold data for a minimum of 10 years without power.

An optional integrator/totalizer can be used to totalize or integrate temperatures up to a maximum display value of 999,999. It features independent scaling and a low temperature cut-out to suit a wide variety of temperature integration applications. A programmable remote input, "E2-CON", is included with the option and can be utilized to control a variety of functions, such as totalizing, alarm control, peak/valley readings, display hold or offset operations, simultaneously with the "E1-CON". Peak/valley (*max/min*) reading memory functions are included with this option and they are easily recalled and controlled by either the front panel or a remote input. All readings are retained at power-down.

Optional dual relays with parallel solid state outputs are fully programmable to operate in a wide variety of modes to suit many control or alarm applications.

Optional 20 mA loop, bi-directional serial communications provides computer and printer interfacing to extend the capabilities of the indicator.

More than one unit can be connected in the loop with other RLC products which have serial communications capabilities.

An optional 4 to 20 mA or 0 to 10 VDC re-transmitted analog output can be scaled by the user to interface with a host of recorders, indicators and controllers. The type of analog output is determined by the model ordered. (See Ordering Information for available models.)

The indicator has several built-in diagnostic functions to alert operators of most malfunctions. Extensive testing of noise interference mechanisms and full burn-in make the indicator extremely reliable in industrial environments. The die-cast front bezel meets NEMA 4/IP65 requirements for washdown applications. Plug-in style terminal blocks simplify installation wiring and change-outs.

THEORY OF OPERATION

The IMY employs a microprocessor to perform the A/D conversion on the input signal via a voltage-to-frequency converter. It digitally scales the result, corrects for meter drift which may be present and then displays the result in a 6-digit display (*4 digits for temperature, 6 digits for totalizer*). The inputs are filtered to enhance the stability of the display. A non-volatile E²PROM provides permanent data retention for operating variables. The display consists of drivers and 6-digit solid-state LEDs. The alarm option employs opto-isolators to isolate the open collector devices from meter common. Operating in parallel, the relays are type Form-C and are rated at 5-amps. The serial communication option features a built-in 20 mA current source and complete opto-isolation. The analog option features a 12-bit DAC and provides a 4 to 20 mA or 0 to 10 VDC output that is digitally scaled. The analog output is isolated from meter common.

BLOCK DIAGRAM

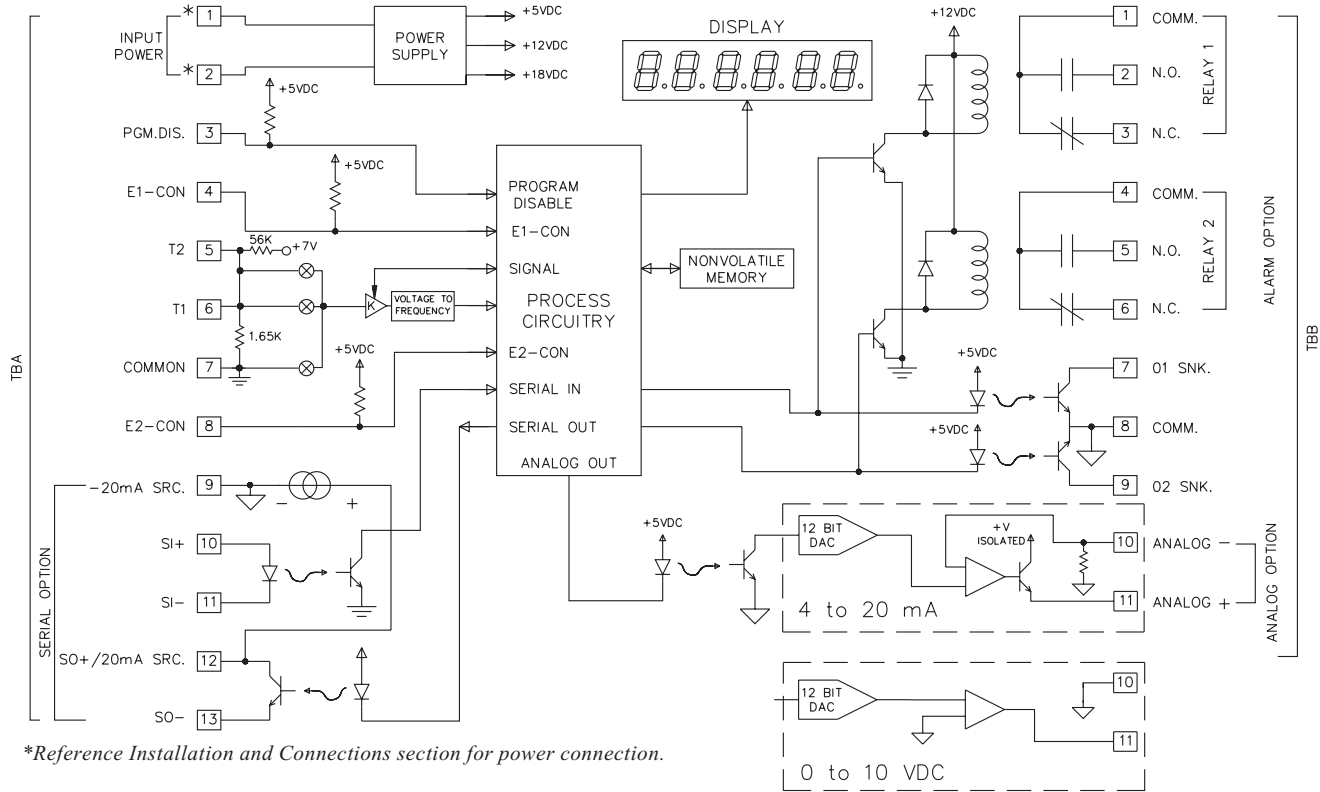

Note: Analog “-” and Alarm common are separate and isolated from the signal common. The commons should NOT be tied together.

PROGRAMMING AND OPERATING THE IMY

PROGRAMMING THE IMY

Although the unit has been programmed at the factory, the set-ups will generally have to be changed to suit the application. Basic set-up is complete after selection of the temperature units, decimal point placement, and selection of the digital filtering level.

Before actually trying to program the indicator, it is advised to organize all the data for the programming steps to avoid any possible confusion and to read the programming procedure entirely before proceeding.

To set-up the indicator, connect primary power and signal wires as outlined in the connections section (*Appendix "A"*). Remove the jumper wire (*if installed*) from TBA #3 (*PGM. DIS.*). This will allow the operator to enter and modify all of the indicator's parameters. Press the front panel button labeled "P", momentarily. Briefly, the display will show "Pro" alternately flashing with "0". This is the indicator's programming mode. The programming mode is divided into sections, numbered 0-9, each of which can be individually accessed. The front panel "UP" and "DOWN" arrow buttons can be used to select one of these numbers and the "P" button can be used to enter the selected programming module. In all of the programming modules, "UP" and "DOWN" are used to either select from a list of choices or enter a value. The "P" button is used to save the new value and progress to the next step within a module (*Note: the new value takes effect when "P" is pressed*). Upon completion of a module, the indicator returns to the "Pro" <> "0" stage. Pressing the "P" button at this time causes the unit to display "End" after which the unit returns to the normal display mode. The following table explains the basic function of each step.

Note: < > This indicates that the display will alternate between the English prompt and the actual data.

DISPLAY**RESULT OF “P” BUTTON**

“Pro” <> “0” - Causes the indicator to return to normal display mode. Any changes to set-up data are permanently stored in the E²PROM.

“Pro” <> “1” - Entry into this module allows the user to select the Thermistor type, whether the display will read in degrees Fahrenheit (F) or Celsius (C), and display decimal point position.

“Pro” <> “2” - Entry into this module allows the user to select non-standard display slope and display offset values. This enables the meter to be “scaled” to a calibrated temperature probe. (*This scaling is NOT required for most applications.*)

“Pro” <> “3” - Module #3 allows the user to program what can be accessed from the front panel when the PGM. DIS. (Program Disable, TBA #3) pin is connected to common. This feature protects critical set-up data from accidental modification while allowing access to setpoints and other functions. The front panel lock-out menu (*quick programming*) includes setpoint modification, integrator/totalizer resetting, and peak/valley resetting.

Note: The term “Quick Programming” is used to refer to the ability to change the information that can be accessed from the front panel when the “PGM. DIS.” terminal is connected to “COMM.”.

“Pro” <> “4” - Module #4 programs the digital filtering level and the function of the remote input “E1-CON” pin (TBA #4), and if the totalizer option is installed, the remote input “E2-CON” pin (TBA #8). The functions of the remote E1 and E2 pins are the same and include display hold, peak/valley modes, totalizer reset, alarm reset, temperature offset, reading synchronization or print request.

DISPLAY**RESULT OF “P” BUTTON**

“Pro” <> “5” - This module sets the time base, scale factor and low temperature disable function for the optional integrator/totalizer.

“Pro” <> “6” - This module allows programming for the basic configuration of the alarm option. The programming includes HI/LO acting, tracking, alarm display, latched or auto-reset, assignment to either the input or the integrator/totalizer, and alarm and hysteresis values.

“Pro” <> “7” - Module #7 is the serial communication parameter programming. Baud rate, unit address, print request function and condensed prints are all programmable.

“Pro” <> “8” - This module allows digital scaling of the retransmitted analog output. Display values that correspond to 4 mA or 0 VDC and 20 mA or 10 VDC are keyed-in to scale the output and it may be assigned to either the input or the integrator / totalizer.

“Pro” <> “9” - This module is the service operation sequence and is not normally accessed by the user. This step re-calibrates the basic input and is used to compensate for long-term drift. Execution of this module should be done by technicians with the proper equipment in accordance with a maintenance plan of yearly recalibrations. A code number entry step is used to protect from inadvertent entries. Also, there is a number of other access codes which provide test and set-up changes as an aid in troubleshooting.

MODULE #1 - PROGRAM THERMISTOR TYPE, TEMPERATURE SCALE (F OR C) AND DECIMAL POINT POSITION

Select the desired Thermistor type by pressing the “UP” or “DOWN” button.

“tYPE” <> “400” 400 = 400 Series, 2,252 ohm
 “700” 700 = Thermoliner™ Series

Select the desired temperature scale by pressing the “UP” or “DOWN” button.

“SCALE” <> “F”
 “C”

Select the desired decimal point location by pressing the “UP” or “DOWN” button.

“dECPnt” <> “0”
 “0.0”

MODULE #2 - PROGRAM TEMPERATURE DISPLAY OFFSET AND SLOPE

If the totalizer option is installed, the offset and slope can be programmed for various temperature probe differences. See the Offset and Slope Display Temperature section for more details.

Select the desired temperature display slope value by pressing the “UP” or the “DOWN” button.

“SLOPE” <> “0.0001” to “10.0000” (ex. 1.0309)

Select the desired temperature display offset value by pressing the “UP” or the “DOWN” button.

“OFFSEt” <> “-.999” to “9999” (ex. -17.5)

MODULE #3 - PROGRAM FUNCTIONS ACCESSIBLE W/ FRONT PANEL LOCKOUT

This programming module programs what is accessible through the front panel when the PGM. DIS. pin is connected to common (COMM.).

Note: The term "Quick Programming" is used to refer to the ability to change the information that can be accessed from the front panel when the "PGM. DIS." terminal is connected to "COMM."

DISPLAY ALARM VALUES

If the alarm option is installed, this selects whether the alarm values will or will not be displayed.

"dSP AL" <> "yES" or "NO"

ENTER ALARM VALUES †

If "YES" was selected for display alarm values, this will select if alarm values may be modified from the front panel. (If "NO" was selected for display alarm values, then this step will default to "NO" and will not be displayed for selection.)

"ENt AL" <> "yES" or "NO"

DISPLAY HYSTERESIS VALUES

If the alarm option is installed, this selects whether the hysteresis values will or will not be displayed.

"dSPHYS" <> "yES" or "NO"

ENTER HYSTERESIS VALUES †

If "YES" was selected for display hysteresis values, this selects whether hysteresis values may be modified from the front panel. (If "NO" was selected for display hysteresis value, then this step will default to "NO" and will not be displayed for selection.)

"ENtHYS" <> "yES" or "NO"

† *Note: This sequence may be locked-out due to other programmed sequences.*

* *Note: This function operates independent of the state of the "PGM. DIS." pin.*

RESET LATCHED ALARMS

If the alarm option is installed and if either alarm is programmed to latch, this will select if a latched alarm(s) can be reset from the front panel.

"rSt AL" <> "yES" or "NO"

DISPLAY PEAK/VALLEY MEMORY BUFFER

If the integrator/totalizer option is installed, this selects whether peak and valley buffers will be displayed.

"dSPbUF" <> "yES" or "NO"

RESET PEAK/VALLEY MEMORY BUFFER †

If "YES" was selected for the previous step, this selects whether the peak and valley buffers may be reset from the front panel. (If "NO" was selected, then this step defaults to "NO" and will not be displayed for selection.)

"rStbUF" <> "yES" or "NO"

SELECT DISPLAY*

If the integrator/totalizer option is installed, this selects whether the display can be switched from input display to total display and from total display to input display.

Note: When "NO" is selected, whatever display (Input or total) is shown, will be the only display accessible.

"SELdSP" <> "yES" or "NO"

RESET TOTAL*

If the integrator/totalizer option is installed, this selects whether the total can be reset from the front panel.

"rSttOt" <> "yES" or "NO"

TEMPERATURE OFFSET VALUE †

If the Integrator/Totalizer/Peak/Valley/Temperature Offset option is installed, this selects whether the programmed offset value will be displayed.

“dSPOFF” <> “yES” or “NO”

ENTER OFFSET VALUE †

If “YES” was selected for the previous step, this selects whether the offset value can be entered from the panel. (If “NO” was selected, then this step defaults to “NO” and will not be displayed for selection.)

“ENtOFF” <> “yES” or “NO”

Depending on functions selected under Pro 3 and Pro 6, alarms, hysteresis, peak, valley and offset values can be monitored and/or changed with PGM. DIS. is tied to COMM. This provides a “QUICK PROGRAMMING” method for “day to day” process changes. (See *QUICK PROGRAMMING SECTION* for more details.)

† Note: This sequence may be locked-out due to other programmed sequences.

*Note: This function operates independent of the state of the “PGM. DIS.” pin.

MODULE #4 - PROGRAM DIGITAL FILTER AND REMOTE INPUT

PROGRAM DIGITAL FILTERING

If the displayed process signal is difficult to read due to small process variations or noise, increased levels of filtering will help to stabilize the display. This programming step may be used in conjunction with display rounding programming (*Pro 1 & 2*) to help minimize this effect. Although the digital filter features a “moving window” to help minimize response time, higher degrees of filtering levels will have slightly longer response times.

“FILter” <> “0” - no digital filtering
 “1” - normal filtering
 “2” - increased filtering
 “3” - maximum filtering

PROGRAM FUNCTION OF E1-CON AND OPTIONAL E2-CON

The function of the remote input “E1-CON” (*TBA #4*) and, if the totalizer option is installed, the remote input “E2-CON” (*TBA #8*) are the same. Functions are activated, as described in the appropriate function, when connected to signal common (*TBA #7*). Whether a function is edge or level activated, it must be held low for a minimum of 20 msec in order for the function to occur. The remote input pins can be used simultaneously and with any combination of functions. When pins are tied together and activated, E1-CON function is generally performed first.

“E1-CON”<> “0” - If the Totalizer/Peak/Valley/Display Offset option is installed, a negative going edge offsets the displayed temperature to zero. (*At the time the E-Pin is activated, the value of the actual temperature being displayed is placed in the location of the display offset value. To bring the unit into the normal temperature display mode, reset the offset value to zero via the front panel.*)

“1” - A negative going edge resets the contents of the totalizer to zero. Totalization commences regardless of the state of the remote input.

“2” - A negative going edge resets the contents of the totalizer to zero and allows totalization as long as the input is low. If the input goes high, totalization is stopped and the contents are saved. This acts as a

totalization enable control from Time 1 to Time 2.

“3” - A low level allows totalization as long as the input is low. If the input goes high, totalization is stopped and the contents are saved. This acts as a totalization enable control from Time 1 to Time 2.

“4” - A low level holds the display (*display hold*). While this input is low, the indicator continues to process the input signal and drive the alarms, totalizer, etc., with the actual signal. The contents of the totalizer are held at the same time the input display is held.

Note: If display hold is activated, and input value is requested via serial, the value on the display will be sent instead of the actual input value at that time.

“5” - A negative going edge resets both peak and valley buffers.
Note: If P/V is called up, a change will not appear on the display until the next time the P/V is called up.

“6” - A negative going edge resets only the peak buffer and the indicator enters a peak reading display mode as long as the input is low. If the input goes high, peak detection and indication are stopped and the last peak reading is retained.

“7” - A negative going edge resets only the valley buffer and the indicator enters a valley reading display mode as long as the input is low. If the input goes high, valley detection and indication are stopped and the last valley reading is retained.

“8” - If the alarm option is installed, a negative going edge resets the latched alarm(s).

*PROGRAM FUNCTION OF E1-CON AND OPTIONAL E2-CON
(Cont'd)*

- “9” - If the alarm option is installed, a low level resets a latched or unlatched alarm into its inactive state. This provides manual override of alarms for system start-up and other unusual events such as system testing.
 - “10” - A negative going edge toggles the display between “*input*” and “*total*” (*from input to total, or vice versa*). No action is taken on the positive going edge.
 - “11” - A negative going edge zeros (*tares*) the input signal and adds the value that was in the input display to the totalizer value, every time this operation is performed. The time-base, scale factor and low cut-out in “*Module #5*” are in affect disabled, when this function is selected.
 - “12” - Display hold with offset. A negative going edge tares (*zeros*) the input signal. Prior to the offset operation, the input signal is saved and held (*display hold*) as long as the remote input pin is low. On the positive edge, the input display will show zero. If there is an increase to the input signal while the remote input is low, the display will reflect (*show*) the increase at the positive edge.
 - “13” - Instrument reading synchronization. A low level disables all meter operations (*alarms, total, analog out, etc.*). A positive edge resets the start of the A/D conversion, to allow synchronization with external processes and controls. While in this function, the other E-CON pin will be operational.
 - “14” - Print request. Transmits data according to the print options that have been selected in Program Module #7. If the low time exceeds 800 msec, a second print-out may occur.
- “E2-CON” <> If the totalizer option is installed, E2-CON has the same programmable functions as E1-CON.

MODULE #5 - PROGRAM INTEGRATOR/TOTALIZER

Programming for the integrator/totalizer consists of four programming steps: totalizer decimal point position, time base, scale factor and low temperature disable. Note that the decimal point position of the integrator/totalizer can be set independent of the decimal point position of the input. The totalizer value will roll over and flash when the total exceeds, 999999 or -99999, indicating an overflow condition. Reverse signal input will cause the totalizer value to count in the opposite direction and eventually no longer be in an overflow condition.

PROGRAM DECIMAL POINT POSITION FOR THE INTEGRATOR/TOTALIZER

The decimal point position for the totalizer are as follows:

“dECPnt” <> “0”
 “0.0”
 “0.00”
 “0.000”
 “0.0000”

PROGRAM INTEGRATOR/TOTALIZER TIME BASE

The time base determines the rate at which readings increase. The integrator/totalizer display is updated $2\frac{1}{2}$ times per second regardless of time base selected, but longer time bases decrease the magnitude of each increase. The three time bases are per second, per minute and per hour. A constant input temperature of 100°, for example, would integrate/totalize to 100° in one second (with a TB of 1 sec.), 100° in one minute (with a TB of 1 min.), and 100° in one hour (with a TB of 1 hr.). (Note: Input changes can be made synchronous to the display by programming E1 or optional E2-CON pin for function 13, Instrument reading synchronization.) A multiplying scale factor may be used to span the standard time ranges (or divide if scale factor < 1). The following equation expresses the integration/totalization process.

$$S.F. = \frac{D.T.}{I.D.} \times \frac{T.B.}{TIME} \times \frac{D.T.D.P.}{I.D.D.P.}$$

S.F. = Programmable Scale Factor
 D.T. = Desired Totalizer value for a fixed time duration
 T.B. = Programmable Time Base

TB = <u>If Program Select Number Chosen Is:</u>	<u>Enter in Formula</u>
“0” for sec.	1
“1” for min.	60
“2” for hr.	3600

I.D. = Input Display Value

TIME = Actual Time period in seconds

D.T.D.P. = <u>Desired Totalizer Value Decimal Point</u>	<u>Enter in Formula</u>
0	1
0.0	10
0.00	100
0.000	1000
0.0000	10000

I.D.D.P. = <u>Input Display Value Decimal Point</u>	<u>Enter in Formula</u>
0	1
0.0	10

“tbASE” <> “0” - per second
 “1” - per minute
 “2” - per hour

PROGRAM THE INTEGRATOR/TOTALIZER SCALE FACTOR

As explained in the previous programming step, a multiplying scale factor can be used to scale the update rate as required. This may be used to span the standard ranges. A scale factor of “1.000” has no effect on the standard ranges.

“SCLFAC” <> “0.001” to “100.000”

PROGRAM THE LOW-END CUTOUT (low temperature level disable)

In order to prevent false integration/totalization in situations where integration/totalization is undesirable, a programmable setpoint can be used to disable integration/totalization when the input temperature falls below this low-end cutout level.

“Lo-cut” <> “-999” to “9999”

MODULE #6 - PROGRAM ALARM/SETPOINT

If the alarm option is installed, this module is used to configure the operation of the alarms to a variety of combinations. The programmable options are HI/LO acting, auto/manual reset (*latching*), tracking, assignment to input or integrator/totalizer, display alarms, alarm values and hysteresis (*deadband*) values.

ALARM TRACKING

With alarm tracking, whenever alarm #2 is changed, alarm #1 will also change so that the offset between alarm #2 and alarm #1 remains the same. This is useful for hierarchical setpoints (*pre-alarm and alarm*) when one change applies to both alarm values. When programming from the front panel, tracking only occurs when PGM. DIS. is low (*front panel lock-out mode, alarm #1 will not appear*). Tracking will always occur if alarm #2 is modified via serial communications independent of PGM. DIS.

“trAc” <> “yES” or “NO”

DISPLAY ALARMS

If display alarms are desired, a message will flash on the display every 5-10 secs when an alarm activates. For alarm 1, the message will flash “AL1 ON” and alarm 2 will flash “AL2 ON”. This warns an operator of an alarm condition. The message will stop when the unit is no longer in an alarm condition.

“dISP” <> “yES” or “NO”

AUTO OR MANUAL RESET FOR ALARM #1

The reset action of alarm #1 may be programmed to reset automatically (*unlatched*) or be programmed to require a manual reset (*latched*), through either a remote input (*E1-CON or optional E2-CON*) or through the front panel. Latched alarms are usually used when an operator is required to take some action for the alarm condition.

“LAtC-1” <> “yES” or “NO”

ALARM #1 ASSIGNMENT TO INPUT OR INTEGRATOR/TOTALIZER

Alarm #1 may be programmed to activate on either the input or the integrator/totalizer value. If the integrator/totalizer option is not installed, this step defaults to the input.

“ASN-1” <> “INPUt” or “totAL”

PROGRAM VALUE FOR ALARM #1

The range of the alarm value is -999 to 9,999 for the input display and -99999 to 999999 for the totalizer option display.

“AL-1” <> “-999” to “99999”

PROGRAM HYSTERESIS VALUE FOR ALARM #1 (Cannot be programmed if alarm latch is programmed)

The hysteresis (*deadband*) value for alarm #1 may be programmed from 1 to 9,999 for the input and 1 to 999999 for the totalizer option. The value is either added to or subtracted from the alarm value depending on whether the alarm is high or low acting. (See “alarm” section for operation.)

“HyS-1” <> “1” to “9999”

ALARM #1 HIGH OR LOW ACTING

The action of alarm #1 may be programmed to activate either when the display value goes above the alarm value (*high acting*) or goes below it (*low acting*).

“Act-1” <> “HI” or “LO”

AUTO OR MANUAL RESET FOR ALARM #2

The reset action of alarm #2 may be programmed to reset automatically (*unlatched*) or be programmed to require a manual reset (*latched*), through either a remote input (*E1-CON or optional E2-CON*) or through the front panel. Latched alarms are usually used when an operator is required to take some action for the alarm condition.

“LAtC-2” <> “yES” or “NO”

ALARM #2 ASSIGNMENT TO INPUT OR INTEGRATOR/ TOTALIZER

Alarm #2 may be programmed to activate on either the input or the integrator/totalizer value. If the integrator/totalizer option is not installed, this step defaults to the input.

“ASN-2” < > “INPUt” or “totAL”

PROGRAM VALUE FOR ALARM #2

The range of the alarm value is -999 to 9,999 for the input display and -99999 to 999999 for the totalizer option display.

“AL-2” < > “-999” to “9999”

PROGRAM HYSTERESIS VALUE FOR ALARM #2

(Cannot be programmed if alarm latch is programmed)

The hysteresis (*deadband*) value for alarm #2 may be programmed from 1 to 9,999 for the input and 1 to 999999 for the totalizer option. The value is either added to or subtracted from the alarm value depending on whether the alarm is high or low acting. *(See “alarms” section for operation.)*

“HyS-2” < > “1” to “9999”

ALARM #2 HIGH OR LOW ACTING

The action of alarm #2 may be programmed to activate either when the display value goes above the alarm value (*high acting*) or goes below it (*low acting*).

“Act-2” < > “HI” or “LO”

Note: Depending on options selected under Pro 3 and Pro 6, alarms, hysteresis, peak, and valley values can be monitored and/or changed when PGM. DIS. is tied to COMM. This provides a “QUICK PROGRAMMING” method for “day to day” process changes. (See QUICK PROGRAMMING SECTION for more details.)

MODULE #7 - PROGRAM SERIAL COMMUNICATIONS

Several programmable parameters must be programmed before serial communication can occur.

BAUD RATE

Select one of the baud rates from the list to match the baud rate of the printer, computer, controller, etc.

“bAud” <> “300”	-	300 baud
“600”	-	600 baud
“1200”	-	1200 baud
“2400”	-	2400 baud

UNIT ADDRESS NUMBER

To allow multiple units to communicate on the 20 mA loop, different address numbers must be assigned to each unit. If only one unit is on the loop, an address of “0” may be given, eliminating the need for the address command.

“AddrES” <> “0” to “99”

PRINT REQUEST FUNCTION

A selection of print operations can be programmed. A print operation occurs when a print request is activated via E1-CON (*TBA #4*) or optional E2-CON (*TBA #8*), or a “P” command is sent from a terminal via the serial communications option. If the option to which a particular print code applies is not installed, then that parameter will not be printed.

If the totalizer is overflowed, an asterisk (*) will precede the digits that are printed (*ex. *000127 positive overflow, -*00127 negative overflow*). If the temperature exceeds the range of the unit, the print-out will show “*OLOLOL*”. If the sensor opens, the print-out will show “*ULULUL*”. For the negative direction or shorted, the print-out will show “*SHOrt*”.

“Print” <> “0” - input signal
“1” - input signal, peak, valley and offset
“2” - input signal, alarm 1 and alarm 2
“3” - input signal, alarm 1, alarm 2, hysteresis 1, hysteresis 2, peak, valley, and offset
“4” - totalizer
“5” - input signal and totalizer
“6” - input signal, totalizer, peak, valley, and offset
“7” - totalizer, alarm 1, and alarm 2
“8” - input signal, totalizer, alarm 1, and alarm 2
“9” - input signal, totalizer, alarm 1, alarm 2, hysteresis 1, hysteresis 2, peak, valley, and offset

FULL OR ABBREVIATED TRANSMISSION

When transmitting data, the IMY can be programmed to suppress the address number, mnemonics and some spaces, if desired, by selecting “NO”. A selection of “NO” results in faster transmission. This feature may be helpful when interfacing with a computer. When interfacing to a printer, a “yES” response is usually desirable.

“FULL” <> “yES” or “NO”

An example of full and abbreviated transmission is shown below:

2 INP -125.7F < CR > < LF > Full transmission
-125.7 < CR > < LF > Abbreviated transmission

MODULE #8 - PROGRAM RE-TRANSMITTED ANALOG OUTPUT

This programming module allows digital scaling of the 4 to 20 mA or 0 to 10 VDC analog output. The type of analog output is determined by the model ordered. (See Ordering Information for available models.) The display value at which 4 mA or 0 VDC and the display value at which 20 mA or 10 VDC are transmitted are keyed-in. The indicator automatically calculates slope and intercept values to complete the scaling. The analog output then follows the calculated display value and as such will update every measurement cycle. The output may also be programmed to proportionally re-transmit the contents of the totalizer instead of the input. Reverse acting output can be achieved by programming the “*high*” display value for the “*AN-LO*” programming step and the “*low*” display value for the “*AN-HI*” step.

Note: DO NOT ADJUST THE ANALOG OUTPUT POTS ON THE BACK OF THE UNIT. Fine offset and span adjustment pots are externally accessible to compensate for small drifts in the output. These pots have been set at the factory and do not normally require adjustment.

ANALOG OUTPUT SOURCE

Program whether the input or the totalizer will serve as the basis for the analog output signal. If the integrator/totalizer option is not installed, then this step defaults to “*Input*”.

“ASIN” <> “INPUt” or “totAL”

ANALOG OUTPUT LO DISPLAY VALUE

Program the display value at which the analog output transmits 4 mA or 0 VDC.

“AN-Lo” <> “-999” to “9999” for “INPUt”
“-99999” to “999999” for “totAL”

ANALOG OUTPUT HI DISPLAY VALUE

Program the display value at which the analog output transmits 20 mA or 10 VDC.

“AN-HI” <> “-999” to “9999” for “INPUt”
“-99999” to “999999” for “totAL”

MODULE #9 - SERVICE OPERATIONS

The indicator has been fully calibrated at the factory. If the unit appears to be indicating incorrectly or inaccurately, refer to the troubleshooting section before attempting this procedure.

When re-calibration is required (*generally every 2 years*), this procedure should only be performed by qualified technicians using appropriate equipment. Resistance source accuracies of 0.01% or better are required.

The procedure consists of applying accurate signal levels to the indicator in a series of two steps. Allow a 30 minute warm-up period before starting this procedure.

Note: *Once the access code has been entered, there is no exiting the program module without completing the calibration procedure.*

ENTER ACCESS CODE

“Code 48” must be keyed-in prior to the calibration sequence to guard against inadvertent entries. Access code numbers other than those listed in this section should not be entered at this step. If any are entered, undefined or unpredictable operation could result.

“CodE” <> “0” to “99”

If the code number for the previous step was not recognized, the indicator returns to “Pro 0”, with no action taken. Otherwise, the calibration procedure is started.

ENTER ZERO REFERENCE

Apply 0 ohms to input by shorting Terminals 6 and 7 as shown in the drawing to the right. Allow to stabilize for 20 seconds before pressing “P”.

“StEP 1” (Press “P”)

APPLY PRECISION RESISTANCE

Connect a precision (0.01%) 5.11 K Ω resistor across Terminals 6 and 7.

Allow to stabilize for 20 seconds before pressing “P”.

“StEP 2” (Press “P”)

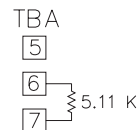

Indicator calibration is complete. It is recommended that calibration be checked by comparing the displayed temperature with a precision thermometer.

SERIAL HARDWARE (loop-back) DIAGNOSTICS

The internal serial communications hardware in the IMY can be tested to verify proper operation. The procedure consists of connecting the Serial Input (SI), Serial Output (SO), and 20 mA Source into a simple loop, and then entering an access code.

Connect the IMY as shown at right. Enter “Pro 9”, key-in “Code 39”, and then press “P”. If the serial communication hardware is OK, “PASS” will be displayed.

Conversely, if there is an internal problem, “FAIL” will be displayed. After the diagnostic test is complete, press “P” to return to “Pro 0”.

“CodE” <> “39”

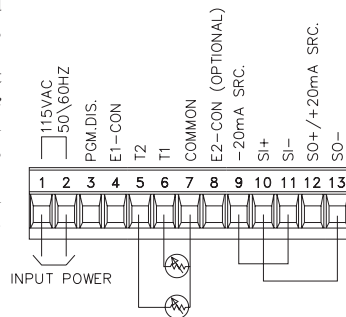

RESTORING ALL PROGRAMMING PARAMETERS BACK TO FACTORY CONFIGURATION

All of the programming in Modules #1 through #8 can be restored back to the factory configuration by entering a specific access code (*refer to the “Factory Configuration” section for the data that will be entered*). The procedure consists of entering “Pro 9”, keying-in “Code 66”, then pressing “P”. The IMY responds by displaying “INITIAL” for several seconds, and then returns to “Pro 0”.

Note: *When this procedure is performed, all of the scaling, presets, etc. that were programmed into the IMY will be overwritten.*

“CodE” <> “66”

OPERATING THE IMY

After completing all set-up operations, the unit is ready to install and operate. After power is applied, a display test consisting of illuminating all segments for 2 seconds is performed. Afterward, the input or total will appear, depending upon the display mode prior to the last power-down. To switch the display to input, press “DOWN” (indicated by “arrows” on the front panel) and to switch it to total, press “UP”. If the integrator/totalizer option is not installed, then display switching to total is inoperative. A minus sign “-” will precede numbers that are negative.

QUICK PROGRAMMING

To limit access to the set-up parameters, connect a key-switch or wire from PGM. DIS. (TBA #3) to COMM. (TBA #7). With this pin connected to common, only a predetermined amount of data can be viewed or altered, as programmed by programming module #3. If “NO” was programmed for all of the available steps in module #3, then pressing “P” will cause the unit to display “Loc”. However, if “YES” was programmed in one or more of the steps, then “P” will invoke entry into a series of commonly modified parameters while protecting the crucial set-up information. This is referred to as the “quick programming” mode. When “quick programming” mode is entered, the alarms and hysteresis values can be modified in the same manner as in the regular programming mode. The new alarm and hysteresis values will take effect when “P” is pressed.

The other operations in the “quick programming” mode require special key sequences as shown:

To reset latched alarm, scroll through steps in “quick programming” mode using the “P” button until “LAtCH1” or “LAtCH2” appears in the display. If they do not appear, they are not latched.

To reset: While “LAtCH1” or “LAtCH2” is being displayed, press and hold “DOWN” and press “P”. Pressing “P” alone causes a step to the next item with no action on the alarm.

To reset peak and valley buffers, scroll through steps in “quick programming” mode using the “P” button until “PEA” or “VAL” appears in the display.

To reset: While “PEA” or “VAL” is being displayed, press and hold “DOWN” and press “P”. Pressing “P” alone causes a step to the next item with no action taken on the buffer.

The front panel buttons are not only used to input data during the programming and “quick programming” mode, but control a number of other functions (if enabled in Pro “3”) as well. In the normal meter mode, these functions are available:

To switch to display of input: Press “DOWN” button.

To switch to display of totalizer: Press “UP” button.

To reset totalizer to zero: Press and hold “UP” and press “P”.

To enter programming or “quick programming”: Press “P”.

After each operation, a message will appear briefly to acknowledge the action.

FACTORY CONFIGURATION

The following chart lists the programming of the unit when shipped from the factory. (In Program Module #9, Code 66 will restore the unit to these values.)

"Pro 1"..... "tYPE" - "700"
"SCALE" - "F"
"dECPNt" - "0.0"

"Pro 2"..... "SLOPE" - "1.0000"
"OFFSEt" - "0.0 F"

"Pro 3"..... "dSP AL" - "yES"
"ENT AL" - "yES"
"dSPHYS" - "yES"
"ENTHYS" - "yES"
"rSt AL" - "yES"
"dSPbUF" - "yES"
"rStbUF" - "yES"
"SELdSP" - "yES"
"rSttOt" - "yES"
"dSPOFF" - "yES"
"ENTOFF" - "yES"

"Pro 4"..... "FILter" - "1"
"E1-CON" - "4" (Display Hold)
"E2-CON" - "4" (Display Hold)

"Pro 5"..... "dECPNt" - "0"
"tbASE" - "0"
"SCLFAC" - "1.000"
"Lo-cut" - "0.0 F"

"Pro 6"..... "trAc" - "NO"
"dISP" - "NO"
"LAtC-1" - "NO"
"ASN-1" - "INPUt"
"AL-1" - "0.0 F"
"HYS-1" - "0.1 F"
"Act-1" - "HI"
"LAtC-2" - "NO"
"ASN -2" - "INPUt"
"AL-2" - "0.0 F"
"HYS-2" - "0.1 F"
"Act-2" - "HI"

"Pro 7"..... "bAud" - "1200"
"AddrES" - "0"
"Print" - "0"
"FULL" - "yES"

"Pro 8"..... "ASIN" - "INPUt"
"AN-Lo" - "0.0 F"
"AN-HI" - "100.0 F"

PROGRAMMING EXAMPLE

As an example of a programming sequence, the following values, gained from a temperature-time monitoring application, are programmed into the indicator.

DISPLAY: Display the actual temperature of a liquid solution in °F.

Activate alarm #1 output when temperature falls below 25°F, activate display alarm. Peak and valley (*max/min*) readings for each cycle to be recorded.

TOTALIZER: When total exceeds 30,000 degree-minutes then latch alarm #2 which stops the heating process and sounds a process complete bell. Reset alarm #2 by remote input. Disable totalization when temperature falls below 200°F. Reset the total from the front panel. Allow switching of the display from/to temperature and total.

SERIAL: Provide hardcopy printout of total, input and peak/valley when operator actuates print request. Baud rate 300.

ANALOG RE-TRANSMISSION: Record temperature profile. 4 mA at 50°F and 20 mA at 200°F.

"Pro 1"..... "tYPE" - Enter 400
 "SCALE" - Enter F
 "dECPNT" - Enter 0

"Pro 2"..... "SLOPE" - Enter 1.0000
 "OFFSET" - Enter 0

"Pro 3"..... "dSP AL" - Enter yes
 "ENT AL" - Enter yes
 "dSPHYS" - Enter no
 "rSt AL" - Enter no
 "dSPbUF" - Enter yes
 "rStbUF" - Enter yes
 "SELdSP" - Enter yes
 "rSttOt" - Enter yes
 "dSPOFF" - Enter no

"Pro 4"..... "FILter" - Enter 1 (Normal)
 "E1-CON" - Enter 7 (reset alarm #2)
 "E2-CON" - Enter 14 (print request)

"Pro 5"..... "tbASE" - Enter 1
 "SCLFAC" - Enter 1.0000
 "Lo-cut" - Enter 200

"Pro 6"..... "trAc" - Enter no
 "dISP" - Enter yes
 "LAiC-1" - Enter no
 "ASN-1" - Enter input
 "AL-1" - Enter 25
 "HYS-1" - Enter 1
 "Act-1" - Enter LO
 "LAiC-2" - Enter yes
 "ASN -2" - Enter total
 "AL-2" - Enter 30000
 "HYS-2" - N/A
 "Act-2" - Enter HI

"Pro 7"..... "bAud" - Enter 300
 "AddrES" - Enter 0
 "Print" - Enter 6
 "FULL" - Enter yes

"Pro 8"..... "ASIN" - Enter input
 "AN-Lo" - Enter 50
 "AN-HI" - Enter 200

TEMPERATURE MONITORING EXAMPLE

An IMY is installed as a monitoring device and back-up controller for a freezer storage facility. Normally, the freezer temperature is maintained at about $-29^{\circ}\text{C} \pm 2^{\circ}$. The absolute maximum allowable temperature of the freezer is 0°C . In the event of a system failure, alarm output #1 of the IMY is programmed to start a secondary cooling system should the temperature reach 0°C . The additional alarm of the IMY is used to signal personnel with a warning bell when the temperature rises above -17°C (indicating a possible failure of the main cooling system). This alarm is programmed to latch in order to assure that personnel inform maintenance of a possible problem. Key switches are installed to lock out the front panel from unauthorized personnel and to provide a means of resetting the latched alarm. The Integrator/totalizer option is specified to store peak and valley temperatures overnight, weekly, etc. Programming module #5 (Pro 5) is used to set up the integrator. The re-transmitted analog output is specified to drive a chart recorder with 4-20 mA for a hard copy of temperature profiles for later evaluation.

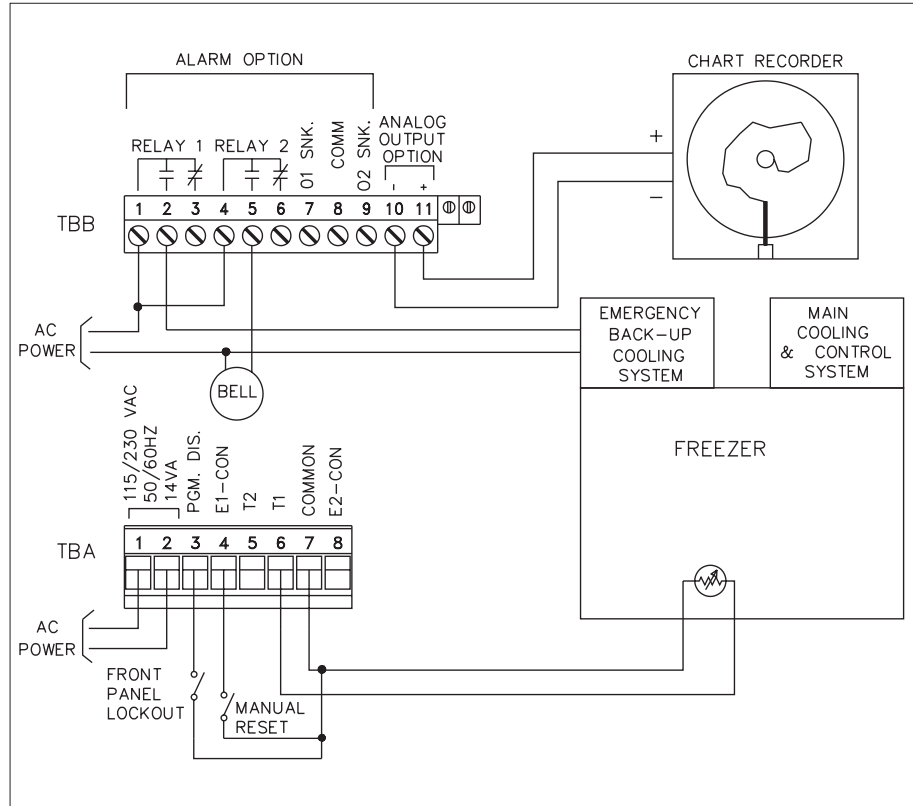

INTEGRATOR / TOTALIZER / PEAK / VALLEY / TEMPERATURE OFFSET (Optional)

INTEGRATOR/TOTALIZER

The integrator/totalizer option simply adds input readings together using a programmable time base and scaling coefficient. The decimal point position of the integrator/totalizer can be programmed independent of the scaled input signal. The integrator/totalizer may be reset through a remote input, by the front panel or through the serial communications option. Alarms may be programmed to trigger from integrator/totalizer values; for example to total “degree minutes” for batching operations. The programmable time bases are “per second”, “per minute” and “per hour”, meaning the integrator/totalizer will accumulate at a fixed rate of 2½ times per second and be equal to a fixed input level over the selected time period. For example, if the input is a constant 100° and the “per minute” time base is selected, the integrator/totalizer will accumulate at the rate of 100° per minute. The totalizer is updated at this rate every 400 msec. As a result, the input is accumulated in “batches” of 6.6 counts every 400 msec. Therefore, the totalizer start and stop sequencing, as well as alarm values set for triggering at specific totalizer values, are only accurate to the 400 msec totalizer update rate. The preceding example requires a scale factor of 1.000 to yield exact time bases, but any scale factor can be used to span between the ranges. (*See section on integrator/totalizer programming for detailed information.*) A programmable low temperature level disable feature completes the integrator/totalizer features (*this will stop totalization when the input drops below this programmed value, “low cut”*). At loss of power to the indicator, the contents of the integrator/totalizer is saved. This will allow integrating/totalizing of interrupted processes. The total can accumulate to 999,999. If the low-end cut-out value is programmed negative (*ex. -100, reference Program Module #5*), and the input display value is between zero and the low-end cut-out value, the totalizer value will decrement. If the input display value goes above zero the total will increment. If the display value goes below (*more negative than*), the low-end cut-out value, totalization will stop.

PEAK/VALLEY

The other features of the integrator/totalizer option are peak and valley detection. The indicator will record the lowest reading (*valley*) and the highest reading (*peak*), automatically, for later recall. This information is

valuable in monitoring the limits of the process over any length of time since these values are stored at power-down to span over shifts, days, etc. An external input can be programmed to reset or engage the unit into a peak/valley reading indicator. Additionally, the peak and valley can be viewed and reset from the front panel, if so programmed, and viewed and reset from the serial communication option.

Note: The peak/valley measurement is not instantaneous, and is based on a nominal 2 sec. response time.

OFFSET AND SLOPE DISPLAY TEMPERATURE

If a difference exists between the displayed temperature and a reference temperature point, the display may be offset for this effect. Similarly, a correcting “slope” may be programmed, with the offset, to allow for two point temperature correction.

For most applications, the slope and offset values are not changed. But if it is required to scale the display to match a calibrated probe, the following formula and example show the calculation of appropriate slope and offset values.

Desired Display = (slope x actual temp. display) + offset

slope = $\frac{\text{difference of two desired temperature points}}{\text{difference of two actual temperature points}}$

offset = one desired temperature point - (slope x one corresponding actual temperature point)

Example:

The meter is displaying 52 degrees and 146 degrees (*actual temperature*) when the calibrated temperature reference shows that 50 degrees and 150 degrees respectively should be displayed (*desired temperature*).

First determine the new slope value using the sets of temperature points.

$$\text{slope} = \frac{150 - 50}{146 - 52} = \frac{100}{94} = 1.0638$$

Next, determine the new offset value by using either one of the temperature pairs.

$$\begin{aligned}\text{offset} &= 150 - (146 \times 1.0638) \\ \text{offset} &= 5.3\end{aligned}$$

OFFSET AND SLOPE DISPLAY TEMPERATURE (Cont'd)

SET-UP:

“Pro 2” “SLOPE” - 1.0638
“OFFSet” - -5.3

This feature allows the operator to manipulate the displayed temperature reading. The operator may utilize this feature for example, when switching thermistor probes, to compensate for differences in thermistor probe accuracy from one manufacturer to another or to offset the input reading to match a “Reference” temperature.

The displayed temperature can be offset either positive or negative to the actual measured temperature. Programming a positive number for the offset value increases the display value. Programming a negative number for the offset value decreases the display value. For example, if the displayed temperature is 10° less than the measured temperature, programming a +10 for the offset value will increase the displayed value by 10 throughout the entire range. If the displayed temperature is 10° higher than the measured temperature, programming a -10 for the offset value will decrease the display value by 10 throughout the entire range.

INTEGRATOR/TOTALIZER EXAMPLE

The indicator is employed to indicate average daily (8 hour) temperature of a “Hot Room” used for storing various ingredients at a large food processing plant. Ingredients which must be kept at temperatures above 100.0°F are stored in this room. The desired constant temperature is 110.0°F. However, frequent opening and closing of the door causes temperature variations. The following programming steps are performed:

BASIC SET-UP

“Pro 1” “tYPE” - 400
“SCALE” - F
“dECPnt” - 0.0

INTEGRATOR/TOTALIZER SET-UP

With an average temperature input which gives a display of 110.0° at the end of an 8 hour time period (*one shift*), the following formula applies:

$$S.F. = \frac{D.T.}{I.D.} \times \left(\frac{T.B.}{TIME} \right) * \times \frac{D.T.D.P.}{I.D.D.P.}$$

S.F. = Programmable Scale Factor

D.T. = Desired Totalizer value for a
fixed time duration

T.B. = Programmable Time Base

T.B. = <u>If Program Select Number Chosen Is:</u>	<u>Enter in Formula</u>
“0” for sec.	1
“1” for min.	60
“2” for hr.	3600

I.D. = Input Display Value

TIME = Actual Time period in seconds

D.T.D.P. = <u>Desired Totalizer Value Decimal Point</u>	<u>Enter in Formula</u>
0	1
0.0	10
0.00	100
0.000	1000
0.0000	10000

I.D.D.P. = <u>Input Display Value Decimal Point</u>	<u>Enter in Formula</u>
0	1
0.0	10

* This value is normally 1, but can be used as a course scale factor of 60 or 3600.

$$\text{S.F.} = \frac{110}{110} \times \left(\frac{3600^{**}}{28800} \right)^* \times \frac{10}{10}$$

(8 Hours x 3600)

$$\text{S.F.} = 1 \times .125$$

$$\text{S.F.} = .125$$

“Pro 5”.....“dECPNt”	- 0.0
“tbASE ”	- 2
“SCLFAC”	- .125
“Lo-cut ”	- 0.0

* This value is normally 1, but can be used as a course scale factor of 60 or 3600.

** Since the time period is in Hrs., the selected T.B. is 3600 (Program select value = 2) which equals per hour (3600 sec.).

The integrator/totalizer will accumulate up to 99999.9. At the end of the shift, the average temperature over the previous 8 hours can be read directly. The integrator/totalizer can then be reset for the next 8 hour shift. Anytime during the shift, the average temperature can be calculated by the following formula:

$$A_v = \frac{I.V.}{S.F. \times T.T.^{***}}$$

I.V. = Integrator/Totalizer Value

S.F. = Programmable Scale Factor

T.T. = Total Time (From the beginning of the shift)

For example, 6 hours and 37 minutes into the shift the integrator/ totalizer reads “90.9”. To find the average temperature up to this point:

$$A_v = \frac{90.9}{.125 \times 6.6166} = \frac{90.9}{.827} \quad A_v = 109.9$$

The average temperature over the last 6 hours and 37 minutes was 109.9°F.

*** Time is in hours. The number of minutes must be divided by 60 and then added to the hours.

ALARMS (Optional)

The alarm option consists of an additional printed circuit board with nine terminals. Six of these terminals are the two Form-C relays and the other three are the two open collector transistors, which act in parallel with the relays. The two alarms are completely independent with programmable values, hysteresis (*deadband*), high or low acting, auto or manual reset, triggering from input or total, and tracking one another, if desired. If the alarms are programmed to latch (*manual reset*), then they will have to be reset either by the front panel or remote input. The alarms can be made to trigger from the integrator/totalizer instead of the input, to activate external alarms, control valves, etc. Additionally, the alarms may be programmed to activate an alarm display to alert operators of the condition.

Alarm #1 can be made to track Alarm #2 by enabling alarm tracking. This is useful in alarm set-ups where a pre-warning control activates before a second

alarm shuts off the process. When tracking is programmed, changing the shut-off trip value (Alarm #2) automatically changes Alarm #1 so that the offset between Alarm #2 and Alarm #1 remains the same. Alarm and hysteresis values can be modified through the optional serial communications to provide automatic control. The following diagrams depict how the alarms work with both “HI” and “LO” acting set-ups.

Programming of the alarms can be accomplished in the normal programming mode “Pro 6” or the unit can be programmed so that the values can only be changed in the “quick programming” mode.

If the display should indicate an “OLOLOL”, “ULULUL”, or “SHort” the alarms will de-energize, whether they are latched or unlatched.

Note: Alarm Comm. (TBB #8) must be kept isolated from analog “-”.

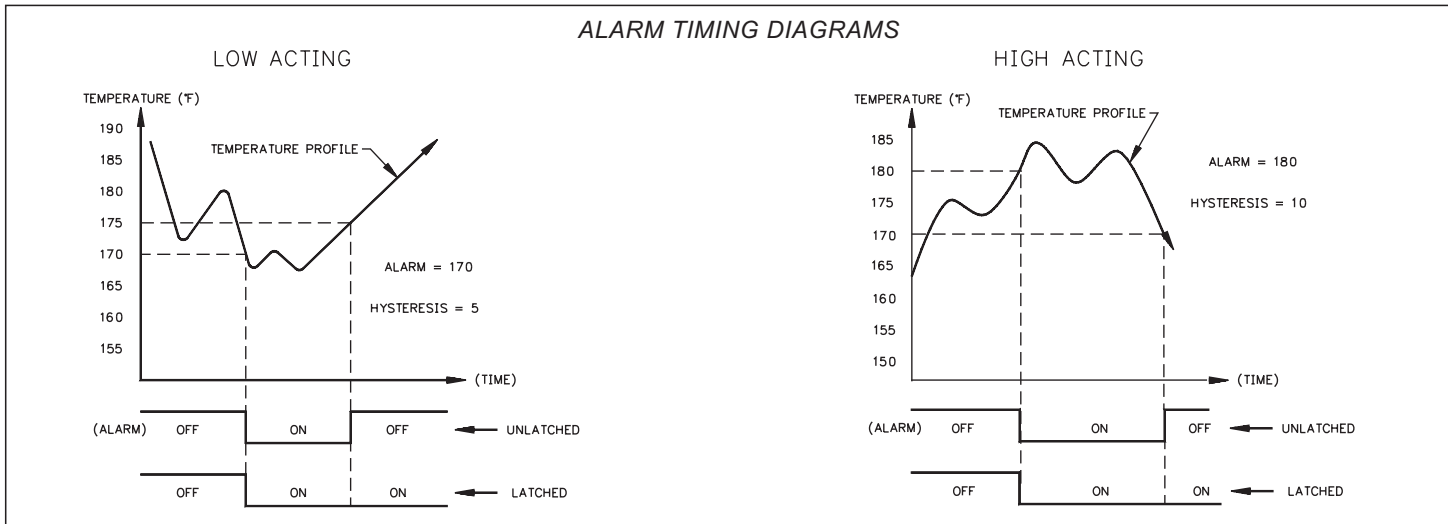

20 mA CURRENT LOOP SERIAL COMMUNICATIONS (Optional)

GENERAL DESCRIPTION

The serial communication option is a half-duplex, two-way, 20 mA loop that can connect to a variety of printers, computers, terminals and controllers to suit many data-polling or automatic operation applications. The indicator responds to a host of commands, including change alarm value, reset totalizer and transmit input value. Two loops are required for all hook-ups; a transmit (*out-going data*) loop and a receive (*in-coming data*) loop. Since the indicator monitors the receive loop for a busy signal (*current interrupted*) while transmitting, the receive loop must be connected even if the indicator is transmitting only, such as to a printer. A built-in 20 mA source can be used in the transmit loop (*only*) by connecting the current return wire to -20 mA SRC., instead of SO+. To bypass the built-in current source, make transmit loop connections to SO+ and SO-. Additionally, multiple units and other Red Lion Controls instruments can be serially addressed, up to a maximum of 99 units. (*The actual number in a single loop is limited by the serial hardware specifications.*) To eliminate problems with ground loops, the serial circuitry is isolated from both signal common and output common. Optional 20 mA to RS232C and 20 mA to RS422 converter modules expand the unit's flexibility.

Note: When operating the unit with a printer, the receive loop of the indicator must have current flowing into it before transmission can take place.

COMMUNICATION FORMAT

Data is sent by switching current on and off in the loop and is received by monitoring the switching action and interpreting the codes that are transmitted. In order for data to be correctly interpreted, there must be identical formats and baud rates among the communicating equipment. The only format available with this indicator is 1 start bit, 7 data bits, 1 odd parity bit and 1 stop bit. The baud rates are programmable and the choices are: 300, 600, 1200 and 2400.

DATA FORMAT-10 BIT FRAME [300, 600, 1200, 2400 Baud]

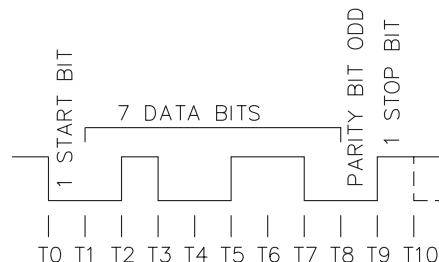

Before serial communication can take place, the indicator must be programmed to the same baud rate as the connected equipment. In addition, the loop address number, print options and full or abbreviated transmission must be programmed. If only one indicator is to be used, then a loop address number of "0" may be used, to eliminate the requirement for the address specifier when sending a command. If more than one indicator is on the loop, assignment of unique addresses, other than zero, for each indicator is recommended. Valid addresses of 0 to 99 may be assigned, but the built-in current source, if used, is capable of driving up to 7 units. Additional drive capability may be afforded by an external current source with a higher compliance voltage. Refer to programming section "Pro 7" to program the serial option.

SENDING COMMANDS TO THE IMY

When sending commands to the unit a command string must be constructed. The command string may consist of command codes, value identifiers, and numerical data. Below is a table outlining the codes the indicator will recognize.

COMMAND	FUNCTIONS
T	transmits the requested information specified by the identifier (A-I, K, and L)
V	change a value specified by the identifier (C-F, K, and L)
N	address a particular indicator in a multiple unit loop (0-99)
R	reset a value specified by the identifier (B-D, G, H, I, and J)
P	print per programmable print options (A-I)

VALUE	IDENTIFIERS	SERIAL MNEMONICS
A	temperature	INP
B	integrator/totalizer	TOT
C	alarm #1	AL1
D	alarm #2	AL2
E	hysteresis #1	HS1
F	hysteresis #2	HS2
G	peak reading	PEK
H	valley reading	VAL
I	zero offset	OFS
J	offset input	
K	analog low	ANL
L	analog high	ANH

Note: RJ - offset the input (re-zeros). When the input is offset (via front panel or "RJ") the amount is stored in the offset reading (I). Ex. When an offset is performed, the display reads "5.0", the offset value will be "-00005.0" (and the display will show 0.0).

A command string is constructed by using the above commands and identifiers along with any data values that are required. The indicator will accept "+" or "-" in front of the data value. Numbers without "+" are understood to be positive. Leading zeros can be eliminated and both lower and upper case characters are accepted. The address command is used to allow a command to be directed to a specific unit on the loop. If the indicator is assigned an address of "0", transmission of the address command is not required. This is done where only one indicator is in the loop.

The command string is constructed in a specific logical sequence. The indicator will reject command strings that do not conform. Only one operation can be performed per command string. Below is a description of how to construct a command string.

1. If the indicator has an address other than zero, the first two characters of the string must consist of the address command (*N*) followed by the unit address number (*0-99*). If the indicator has an address of 0, the address command is optional.
2. The next two characters in the string are the actual command the indicator must perform and the identifier on which it operates. Command P-print, Value I-zero offset and J-offset input, have implied operators and need no additional characters.
3. If the change value command is being used (*V*), the next characters in the string after the value identifier, are the numerical data. When sending numerical data, such as change an alarm value, the correct number of digits to the right, must be included. As an example, to change an alarm value from 150.2 to 50.0. Sending 50 would cause the indicator to see 5.0 and change the alarm value accordingly.
4. All commands must be terminated by an asterisk(*). The indicator will not respond to any other code. Carriage return and line feed are not valid terminators and should be suppressed with the character ";", if using a BASIC print statement (*ex. Print "N9TA*";*).

COMMAND STRING EXAMPLES

Indicator with address 3, transmit temperature reading.
N3TA*

Indicator with address 0, change alarm #1 to 150.
VC150*

Indicator with address 1, reset totalizer.
N1RB*

Indicator with address 99, print the print options.
N99P*

Indicator with address 0, zero the offset value.
RI*

If illegal commands or characters are sent to the IM, an asterisk (*) must be sent to clear the input buffer. The IM will not respond to an illegal or incomplete transmission. The diagrams show the difference in the timing considerations for either Abbreviated or Full Character Transmission, or if a Reset Command is issued.

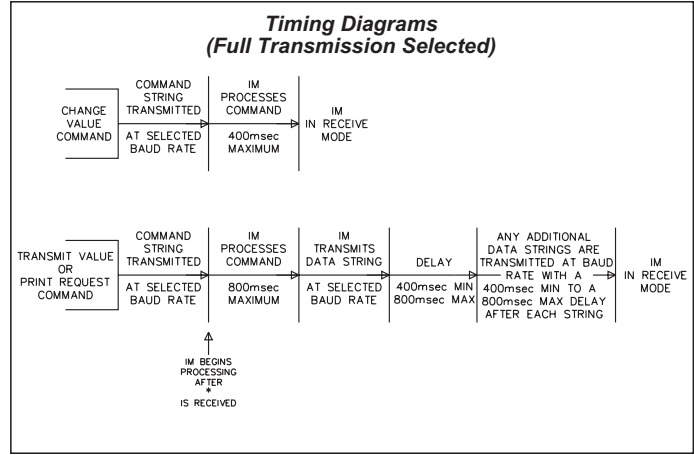
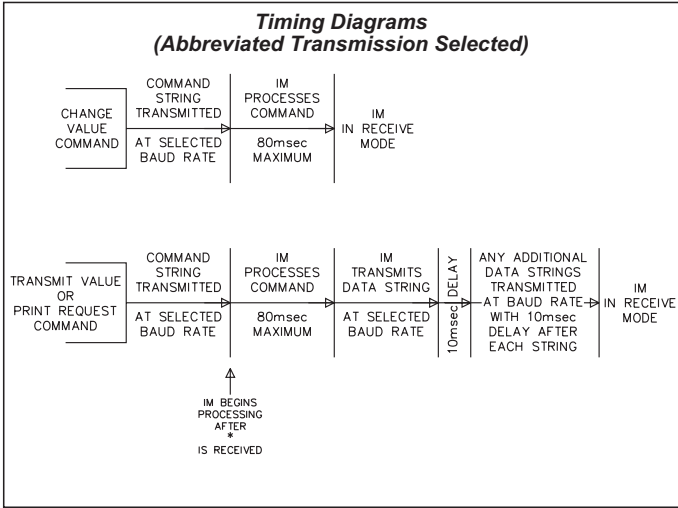

Note: If Full Transmission is selected and the front panel is being accessed at the time of transmission, the IM may take as long as 2 seconds to respond.

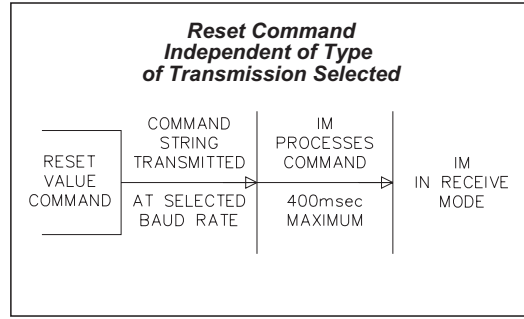

RECEIVING DATA FROM THE IMY

Data is transmitted from the indicator whenever a “T” or “P” command is received via serial communications or a remote input, E1-CON or optional E2-CON pin is programmed for print request, is activated. If the abbreviated transmission was programmed, just data will be transmitted with no built-in delay. (If full transmission is programmed, then there is a 400 msec min to 800 msec max delay built-in to the string.)

A data string transmission is shown below.

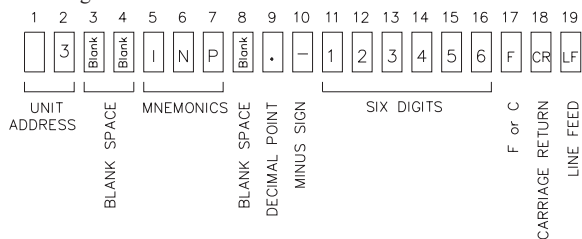

The first two characters transmitted are the unit address number, unless it is zero, in which case it is left blank. Then two blank spaces are sent. The next three characters are the abbreviation for the value (mnemonics), which is then followed by a blank. The actual data is transmitted next. The field is right justified with leading zeros. Negative numbers are indicated by a minus sign fixed next to the identifier. A carriage return and a line feed are transmitted next. For various reasons, “extra” characters are added onto the end of the above character string. (These characters could be and are used for control or signaling purposes.) These characters are:

< CR> sent after single line transmissions from IM unit.

< SP>< CR>< LF> sent after “last line of a block” transmission from IM.

For a “T” command or after each “line of a block” transmission, no additional characters are sent. If the abbreviated transmission is selected, the address, mnemonics, and any blank spaces (first eight characters) are not transmitted (the data strings are left justified in this case).

If the transmitted data is overrunning the peripheral’s buffer, the receive channel to the indicator may be used for handshaking purposes. As a consequence of this, even if the indicator is to transmit only (ex. to a printer), current must be flowing in the receive channel to allow transmission.

Examples of transmissions are as follows:

2 INP -125.7F < CR> < LF> full transmission

-125.7 < CR> < LF> abbreviated transmission

CURRENT LOOP INSTALLATION

WIRING CONNECTIONS

When wiring the 20 mA current loop, remove the bottom terminal block (TBA), located on the rear of the unit. Refer to the numbers listed with the terminal descriptions below or those located on the label. It is recommended that shielded (screened) cable be used for serial communications. This unit meets the EMC specifications using Alpha #2404 cable or equivalent. There are higher grades of shielded cable, such as four conductor twisted pair, that offer an even higher degree of noise immunity. Install each wire in its proper location on the terminal block. When all connections are made, replace the terminal block into its proper location.

SERIAL TERMINAL DESCRIPTIONS

- PRINT REQ.** - The Print Request terminal is pulled low to activate the unit to transmit data according to the print function selected in Program Module #7 (*Reference Programming Module #7 for more details*). In order for a print request function to occur, E1-CON (TBA #4) or E2-CON (TBA #8) must be programmed for print request. *Note: In order to guarantee a print-out, the programmed E-CON pin must be held low for at least 20 msec. If this time exceeds 800 msec, a second print-out may occur.*
- 20 mA SRC.** - 20 mA current source return path for the transmit loop. Current flows into this pin.
- SI+ (Serial In+)** -
- SI- (Serial In-)** -
The unit receives commands on the SI terminals. They are connected in series with the transmit or output terminals of the device to be connected.
- SO+ / +20 mA SRC. (Serial Out+)** - 20 mA current source for the transmit loop (internally connected).
- SO- (Serial Out-)** -
The unit transmits the requested data on the SO terminals. They are connected in series to the receive input of the device to be connected.

Note: The Serial Input terminals must be held in the mark condition (current flowing) in order for the unit to respond to a Print Request terminal activation.

SERIAL COMMUNICATIONS EXAMPLES

CONNECTING TO AN RLC PRINTER

The drawing shows the indicator with the 20 mA Serial Communication Option set-up with an RLC Model DMPC printer. An external current source is required to implement the printer's busy signal to the indicator's receive loop, which prevents overruns. The "Print switch" is a momentary contact, push button type connected between the E2-CON (TBA #8) and the signal common (TBA #7). The print function and E2-CON must be programmed and the baud rate must match those of the printer. If a printer is used which does not have a 'busy' line, current must still be flowing into the indicator's receive loop before transmission can occur.

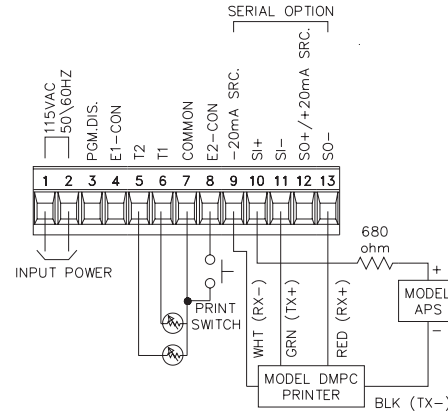

PROCESS CONTROLLING SYSTEM

Six Model IMYs with Serial Communication Option are used to monitor and control the temperature of 6 ovens at a large bakery. The IMYs are located at each of the ovens in the production area of the building. The communications lines are run to an industrial computer located in the production offices.

The drawing below shows the Current Loop set-up. Each IMY is given an address and programmed accordingly (*Program Module #7*). A baud rate of 1200 is selected.

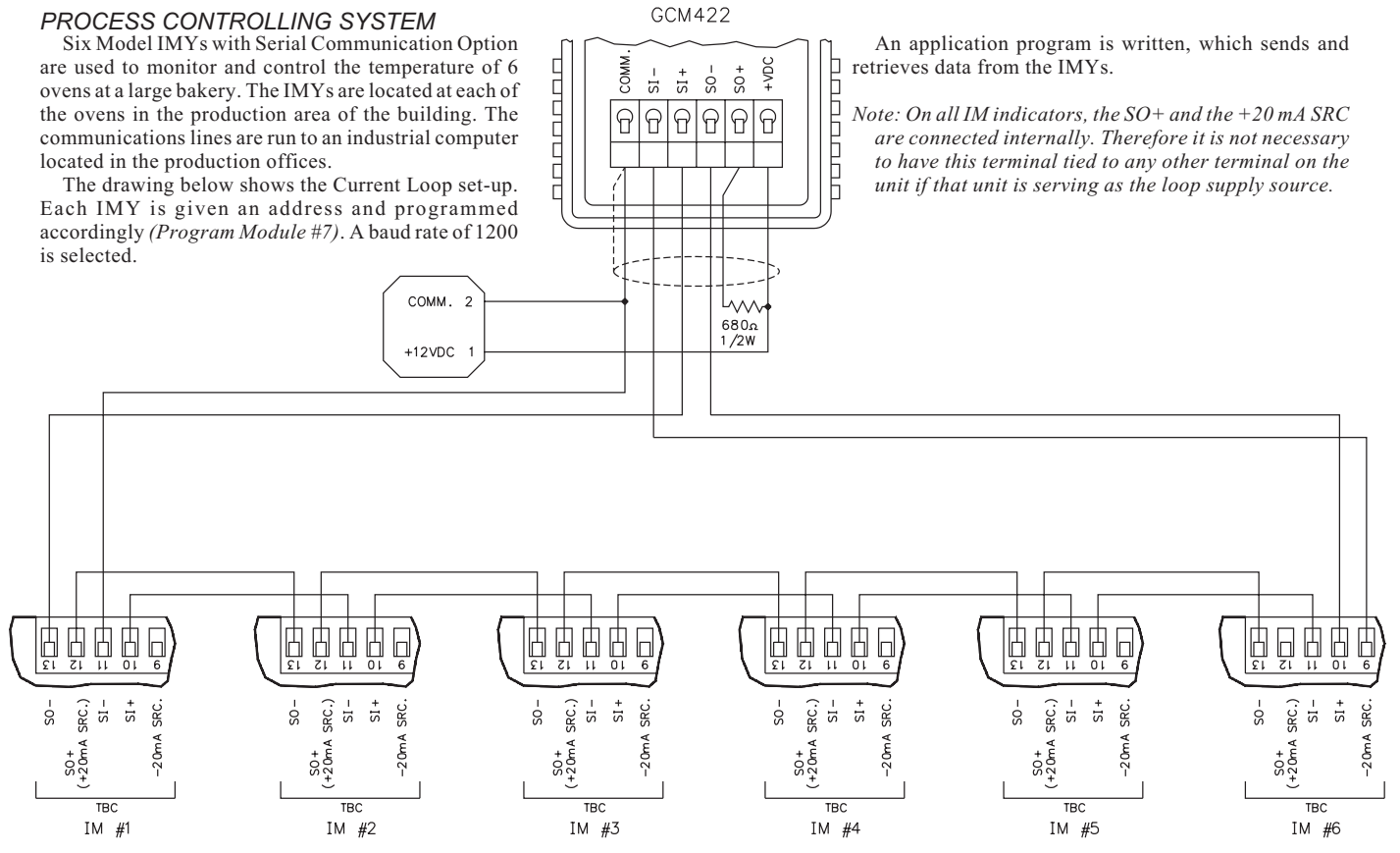

An application program is written, which sends and retrieves data from the IMYs.

Note: On all IM indicators, the SO+ and the +20 mA SRC are connected internally. Therefore it is not necessary to have this terminal tied to any other terminal on the unit if that unit is serving as the loop supply source.

RE-TRANSMITTED ANALOG OUTPUT (Optional)

The re-transmitted analog output option transmits a digitally programmable 4 to 20 mA or 0 to 10 VDC signal to drive chart recorders, remote indicators and controllers. The option is contained on the upper PCB and has two outputs, "ANALOG-" (TBB #10) and "ANALOG+" (TBB #11) and is self-powered (*active*) with a compliance of 10 VDC. The analog "-" output is isolated from the input common, eliminating problems from ground loops. Programming of the option is performed in "Pro 8" of the normal programming mode. Display values are simply keyed in to provide a 4 mA or 0 VDC output, "AN-Lo", and a 20 mA or 10 VDC output, "AN-HI". The analog output then follows the assigned value and as such will update every measurement cycle. Nonstandard current or voltage ranges can be supported

by calculating the slope and intercept of the display/output and calculating the required display values at 4 mA or 0 VDC and 20 mA or 10 VDC. Reverse action can be achieved by programming a "high" display value for "AN-Lo" and a "low" display value for "AN-HI".

If the display should indicate an "OLOLOL", "ULULUL", or "SHort" the analog output will go to 20 mA or 10 VDC for an "OLOLOL" or "SHort", and 4 mA or 0 VDC for a "ULULUL".

Note: Analog "-" must be kept isolated from Alarm Comm. (TBB #8).

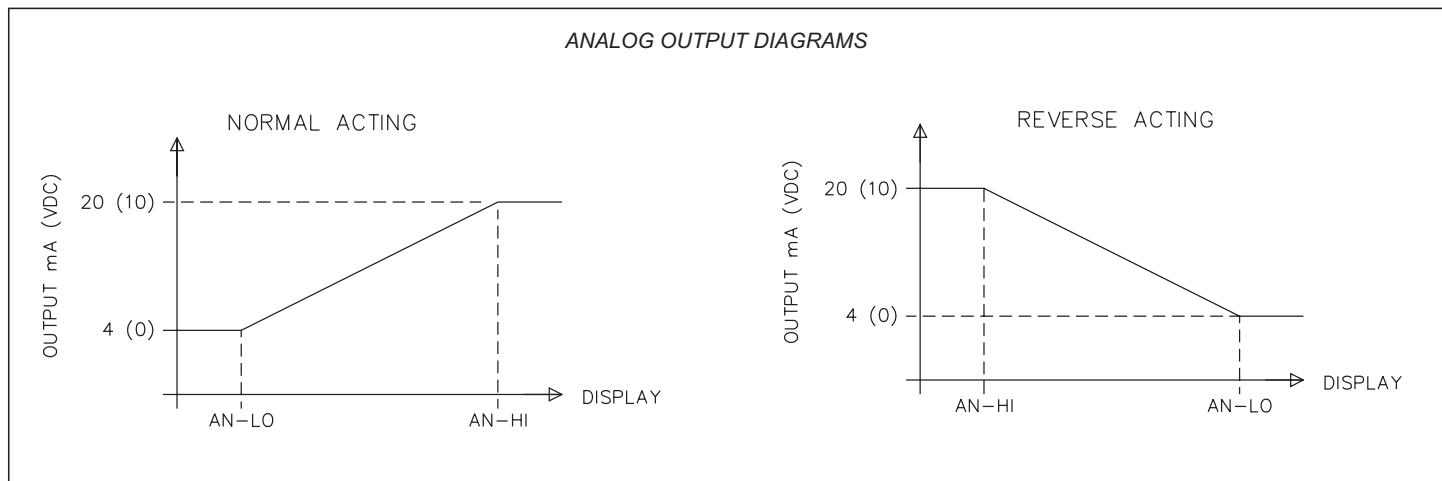

ANALOG OUTPUT CALIBRATION

Although the analog output has been calibrated at the factory, zero and span adjustments are provided to compensate for small offsets and drifts. If excessive drift is noticed, the following calibration procedure may be performed.

Scale the analog output by entering an arbitrarily larger display value for “AN-HI” then for “AN-LO”, in “PRO 8”.

Note: Set the analog output source assignment for input.

4 to 20 mA Calibration

Exit the programming mode and apply a *(temperature)/(resistance)* to the input of the indicator so that the display reading is below that of the value entered for “AN-LO”. Adjust the zero potentiometer (*right side*) so that exactly 4.00 mA flows, as verified by an accurate ammeter. Next, apply a *(temperature)/(resistance)* to the indicator so that the display reading is above that of the value entered for “AN-HI”. (See Appendix “B” for max. input voltage.) Adjust the span potentiometer (*left side*) so that 20.00 mA is flowing. Repeat the zero and span adjustments until both are accurate. Analog output calibration is complete.

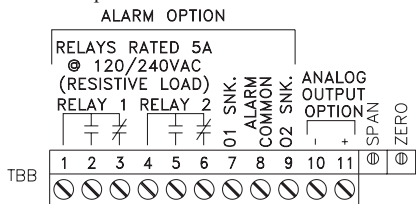

0 to 10 VDC Calibration

Exit the programming mode and apply a *(temperature)/(resistance)* to the input of the indicator so that the display reading is below that of the value entered for “AN-LO”. Adjust the zero potentiometer (*right side*) so that exactly 0.00 VDC flows, as verified by an accurate voltmeter. Next, apply a *(temperature)/(resistance)* to the input of the indicator so that the display reading is above that of the value entered for “AN-HI”. (See Appendix “B” for max. input voltage.) Adjust the span potentiometer (*left side*) so that 10.00 VDC is flowing. Repeat the zero and span adjustments until both are accurate. Analog output calibration is complete.

APPENDIX "A" - INSTALLATION & CONNECTIONS

INSTALLATION ENVIRONMENT

The unit should be installed in a location that does not exceed the maximum operating temperature and provides good air circulation. Placing the unit near devices that generate excessive heat should be avoided.

The bezel should be cleaned only with a soft cloth and neutral soap product. Do NOT use solvents. Continuous exposure to direct sunlight may accelerate the aging process of the bezel.

PANEL INSTALLATION

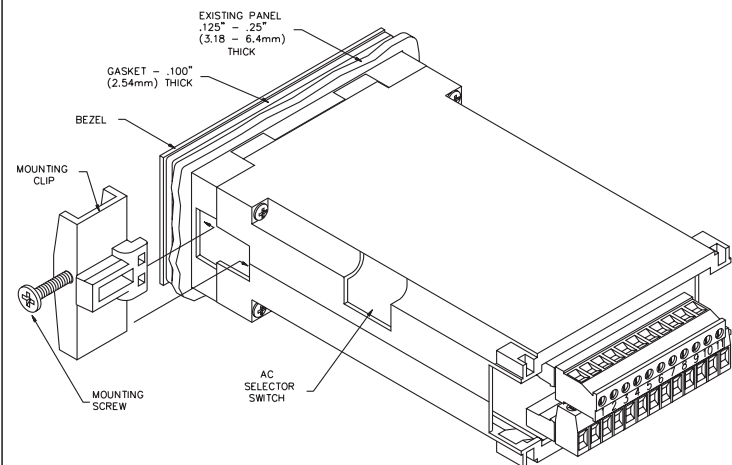

Do not use tools of any kind (screwdrivers, pens, pencils, etc.) to operate the keypad of the unit.

Before installing the IM into the panel, the user should first become familiar with the unit. It may also be desirable to program the unit for the application. When programming is complete, all parameters will be saved in non-volatile memory. The Program Disable (PGM.DIS.) terminal should be connected to COMM. to prevent accidental or unauthorized programming changes.

The unit meets NEMA 4/IP65 requirements for indoor use, when properly installed. The units are intended to be mounted into an enclosed panel with a gasket to provide a water-tight seal. Two mounting clips and screws are provided for easy installation. Consideration should be given to the thickness of the panel. A panel which is too thin may distort and not provide a water-tight seal. Recommended minimum panel thickness is 1/8".

After the panel cut-out has been completed and deburred, carefully slide the gasket over the rear of the unit to the back of the bezel. Insert the unit into the panel. As depicted in the drawing, install the screws into the narrow end of the mounting clips. Thread the screws into the clips until the pointed end just protrudes through the other side. Install each of the mounting clips by inserting the wide lip of the clips into the wide end of the hole, located on either side of the case. Then snap the clip onto the case. Tighten the screws evenly to apply uniform compression, thus providing a water-tight seal.

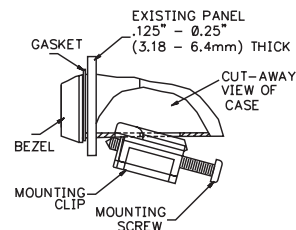

Caution: Only minimum pressure is required to seal panel. Do NOT overtighten screws.

SELECT AC POWER (115/230 VAC)

The AC power to the unit must be selected for either 115 VAC or 230 VAC. The selector switch is located through an access slot on the side of the case (See figure above or label on case). The unit is shipped from the factory with the switch in the 230 VAC position.



Caution: Make sure the AC selector switch is set to the appropriate position before applying power to the unit. Damage to the unit may occur if the AC selector switch is set incorrectly.

EMC INSTALLATION GUIDELINES

Although this unit is designed with a high degree of immunity to ElectroMagnetic Interference (EMI), proper installation and wiring methods must be followed to ensure compatibility in each application. The type of electrical noise, source or coupling method into the unit may be different for various installations. In extremely high EMI environments, additional measures may be needed. The unit becomes more immune to EMI with fewer I/O connections. Cable length, routing and shield termination are very important and can mean the difference between a successful or a troublesome installation. Listed below are some EMC guidelines for successful installation in an industrial environment.

1. The unit should be mounted in a metal enclosure, which is properly connected to protective earth.
 - a. If the bezel is exposed to high Electro-Static Discharge (ESD) levels, above 4 Kv, it should be connected to protective earth. This can be done by making sure the metal bezel makes proper contact to the panel cut-out or connecting the bezel screw with a spade terminal and wire to protective earth.
2. Use shielded (screened) cables for all Signal and Control inputs. The shield (screen) pigtail connection should be made as short as possible. The connection point for the shield depends somewhat upon the application. Listed below are the recommended methods of connecting the shield, in order of their effectiveness.
 - a. Connect the shield only at the panel where the unit is mounted to earth ground (protective earth).
 - b. Connect the shield to earth ground at both ends of the cable, usually when the noise source frequency is above 1 MHz.
 - c. Connect the shield to common of the unit and leave the other end of the shield unconnected and insulated from earth ground.
3. Never run Signal or Control cables in the same conduit or raceway with AC power lines, conductors feeding motors, solenoids, SCR controls, and heaters, etc. The cables should be run in metal conduit that is properly grounded. This is especially useful in applications where cable runs are long and portable two-way radios are used in close proximity or if the installation is near a commercial radio transmitter.
4. Signal or Control cables within an enclosure should be routed as far away as possible from contactors, control relays, transformers, and other noisy components.

5. In extremely high EMI environments, the use of external EMI suppression devices, such as ferrite suppression cores, is effective. Install them on Signal and Control cables as close to the unit as possible. Loop the cable through the core several times or use multiple cores on each cable for additional protection. Install line filters on the power input cable to the unit to suppress power line interference. Install them near the power entry point of the enclosure. The following EMI suppression devices (or equivalent) are recommended:

Ferrite Suppression Cores for signal and control cables:

Fair-Rite # 0443167251 (RLC #FCOR0000)

TDK # ZCAT3035-1330A

Steward #28B2029-0A0

Line Filters for input power cables:

Schaffner # FN610-1/07 (RLC #LFIL0000)

Schaffner # FN670-1.8/07

Corcom #1VR3

Note: Reference manufacturer's instructions when installing a line filter.

6. Long cable runs are more susceptible to EMI pickup than short cable runs. Therefore, keep cable runs as short as possible.
7. Switching of inductive loads produces high EMI. Use of snubbers across inductive loads suppresses EMI.

Snubbers:

RLC #SNUB0000

WIRING CONNECTIONS

After the unit has been mechanically mounted, it is ready to be wired. All conductors should meet voltage and current ratings for each terminal. Also cabling should conform to appropriate standards of good installation, local codes, and regulations. It is recommended that power supplied to the unit be protected by a fuse or circuit breaker. All wiring connections are made on removable plug-in terminal blocks. There is a separate terminal block for the bottom board (TBA) and optional top board (TBB). When wiring the unit, remove the terminal block and use the numbers on the label to identify the position number with the proper function. Strip the wire, leaving approx. 1/4" bare wire exposed (stranded wires should be tinned with solder). Insert the wire into the terminal and tighten down the screw until the wire is clamped tightly. Each terminal can accept up to one 14-gauge, two 18-gauge or four 20-gauge wire(s). After the terminal block is wired, install it into proper location on the PC board. Wire each terminal block in this manner.

POWER WIRING

Primary AC power is connected to terminal 1 and 2 (marked VAC 50/60 Hz, located on the left hand side of the bottom terminal block). To reduce the chance of noise spikes entering the AC line and affecting the indicator, the AC power should be relatively "clean" and within the specified $\pm 10\%$ variation limit. Drawing power from heavily loaded circuits or circuits which also power loads that cycle on and off, (contactors, relays, motors, machinery, etc.) should be avoided.

SIGNAL WIRING (THERMISTOR)



Meter signal input common is not isolated from PGM. DIS., E1-CON, E2-CON; maximum allowable 50 V can be present in the circuit that is being measured.

Thermistors provide a higher degree of accuracy, stability, and resolution over other temperature sensing elements, such as platinum RTDs or thermocouples.

The IMY supports two popular types of thermistors, the 400 Series (YSI 44000) 2,252 Ω thermistor, and the 700 Series "Thermoliner™" thermistor. Selection of the two types is done in Programming Module #1.

The 400 Series thermistor is a 2-wire sensor. One lead connects to TBA #6 (T1) and the other lead connects to TBA #7 (comm).

The 700 Series Thermoliner™ thermistor is a 3-wire sensor. One lead connects to TBA #6 (T1) and the common lead connects to TBA #7 (comm). The third wire is an additional thermistor lead and connects to TBA #5 (T2).

Always refer to the sensor manufacturer's instructions for probe wiring connections, if available.

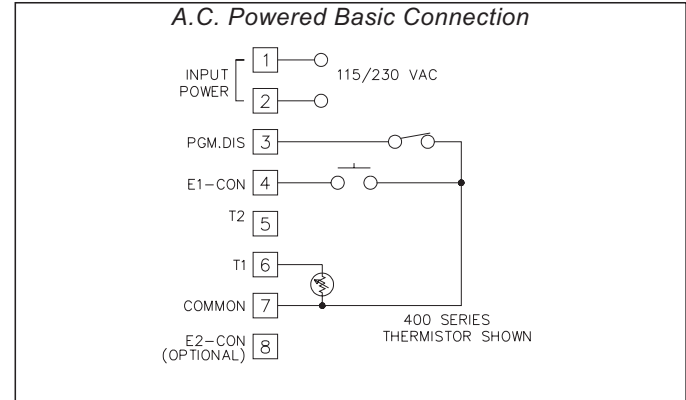

USER INPUT WIRING

User inputs (PGM.DIS., E1-CON, and optional E2-CON) are digital inputs that are active when connected to TBA #5 Common. Any form of mechanical switch, sinking collector logic with less than 0.7 V saturation may be used. The use of shielded cable is recommended. Follow the EMC Installation Guidelines for shield connection.

OUTPUT WIRING

Relay Connections

To prolong contact life and suppress electrical noise interference due to the switching of inductive loads, it is good installation practice to install a snubber across the contactor. Follow the manufacturer's instructions for installation.

Note: Snubber leakage current can cause some electro-mechanical devices to be held ON.

APPENDIX "B" - SPECIFICATIONS AND DIMENSIONS

- DISPLAY:** 4-digit with F/C indication, 0.56" (14.2 mm) high LED, minus sign displayed for negative temperatures. 6-digits for integrator/totalizer. "Flashing" display for totalizer overflow. "ULULUL" displayed for input overload and "OLOLOL" displayed for underload (*negative overload*).
- POWER REQUIREMENTS:** Switch selectable 115/230 VAC, $\pm 10\%$, 50/60 Hz, 14 VA.
Isolation: 2300 Vrms for 1 min. To all inputs and outputs.
 Working Voltage: 300 V max., CAT II
- CONTROLS:** Three front panel push buttons for modifying alarm values and indicator set-up. Two external inputs for disabling the front panel and controlling programmable functions.
- SIGNAL INPUT:** 2-Wire, 400 Series 2,252 ohm Thermistor; or 3-wire, 700 Series Thermoliner™ thermistor.
Max. Input Signal Voltage: ± 15 VDC.
 Input Common potential with respect to earth Common: 50 V max., CAT I
- OPEN THERMISTOR DETECTION:**
Display - "ULULUL"
Setpoint Outputs - Disabled (*Deactivated*)
Serial Output - "ULULUL" in data field
Integration/Totalization - Disabled
Analog Output - 4 mA
- RANGE:** 400 Series -40.0° to 125.0°C (-40.0° to 257°F)
 700 Series -30.0° to 100.0°C (-22.0° to 212°F).
- RESOLUTION:** 0.1 or 1 degree.
- ACCURACY:** $\pm 0.2^\circ\text{C}$ (0.36°F) $\pm \frac{1}{2}$ LSD, @ 23°C and 10 min. warm-up.
- READING RATE:** 2.5 readings/second
- RESPONSE TIME:** 2 seconds to settle for step input (*increases with programmable digital filtering*)
- NORMAL MODE REJECTION:** 40 dB at 50/60 Hz (*may be improved by programmable digital filtering*)
- COMMON MODE REJECTION:** 120 dB, DC to 50/60 Hz
- INTEGRATOR/TOTALIZER:** Front panel button for input/total display select. External integrator/totalizer reset/enable. Programmable time-base, scale factor (0.001-999.999) and low-temp cut-out. Maximum response time 0.2 sec.
- E1-CON & E2-CON:** External remote inputs which allow activation of various functions. (Reset total, peak indicator mode, trigger mode, etc.)
 $V_{IL} = 0.8 V_{MAX}$; $V_{IH} = 2.0 V_{MIN}$; Response Time = 0.2 sec. Maximum.

DIMENSIONS In inches (mm)

Note: Recommended minimum clearance (behind the panel) for mounting clip installation is 2.1" (53.3) H x 5.5" (140) W.

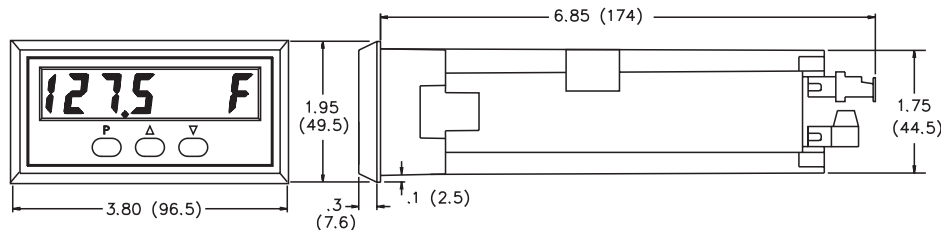

PANEL CUT-OUT

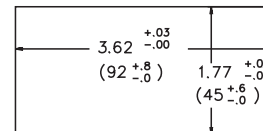

15. ENVIRONMENTAL CONDITIONS:

Operating Temperature Range: 0 to 50°C

Storage Temperature Range: -40 to 80°C

Operating and Storage Humidity: 85% max. relative humidity (non-condensing) from 0°C to 50°C.

Altitude: Up to 2000 meters

16. SERIAL COMMUNICATIONS (Optional):

Isolation To Signal Input Common: 500 Vrms for 1 min.

Working Voltage: 50 V max., CAT I

Not isolated from all other commons.

Type: Bi-directional 20 mA current loop, 20 mA source provided on transmit loop. (*Powers up to 7 units in a loop with internal current source*).

Baud Rate: programmable 300 to 2400

Maximum address: 99 (*Actual number in a single loop is limited by serial hardware specifications.*)

Data Format: 10 bit frame, Odd parity (*one start bit, 7 data bits, one odd parity bit, and one stop bit.*)

Serial Hardware Specifications:

SO - Output Transistor Rating: $V_{\max} = 30 \text{ VDC}$, $V_{\text{SAT}} = 1 V_{\max}$ at 20 mA.

Note: This will allow up to 28 units maximum in each loop.

SI - Input Diode Rating: $V_F = 1.25 V_{\text{TYP}}$; $1.5 V_{\text{MAX}}$

Note: The compliance voltage rating of the source must be greater than the sum of the voltage drops around the loop. (Typically a 30 VDC powered source would be capable of operating between 18 and 22 units in a loop.)

17. ALARMS (Optional):

Solid State: Two, isolated, sinking open collector NPN transistors acting in parallel with relays. $I_{\max} = 100 \text{ mA}$. $V_{\text{SAT}} = 1.0 \text{ V @ } 100 \text{ mA}$. $V_{\max} = 30 \text{ VDC}$.

Isolation To Signal Input Common: 500 Vrms for 1 min.

Working Voltage: 50 V max., CAT I

Not isolated from all other commons.

Relays:

Isolation To Signal Input Common: 2300 Vrms for 1 min.

Working Voltage: 300 V max., CAT II

Type: Form C (2)

Max. Rating: 5 Amps @ 120/240 VAC or 28 VDC (*resistive load*), 1/8 hp @ 120 VAC (*inductive load*).

Relay Life Expectancy: 100,000 cycles at max. rating. (As load level decreases, life expectancy increases.)

18. ANALOG OUTPUT (Optional): Digital scaling and offsetting

Isolation To Signal Input Common: 500 Vrms for 1 min.

Working Voltage: 50 V max., CAT I

Not isolated from all other commons.

4 to 20 mA:

Accuracy: 0.1% of full scale

Resolution: 12 bits

Compliance Voltage: 10 VDC (*500 Ω max. loop resistance*)

0 to 10 VDC:

Accuracy: $\pm(0.1\%$ of reading + 35 mV)

Resolution: 12 bits

Min. Load Resistance: 10 K Ω (1 mA max.)

19. PEAK/VALLEY/SLOPE/OFFSET (Optional):

Peak and Valley recording. Programmable temperature offset and slope.

20. CERTIFICATIONS AND COMPLIANCES:

SAFETY

IEC 1010-1, EN 61010-1: Safety requirements for electrical equipment for measurement, control and laboratory use, Part 1.

IP65 Enclosure rating (Face only), IEC 529

Type 4 Enclosure rating (Face only), UL50

ELECTROMAGNETIC COMPATIBILITY

Immunity to EN 50082-2

Electrostatic discharge	EN 61000-4-2	Level 2; 4 Kv contact ¹ Level 3; 8 Kv air Level 3; 10 V/m ²
Electromagnetic RF fields	EN 61000-4-3	80 MHz - 1 GHz
Fast transients (burst)	EN 61000-4-4	Level 4; 2 Kv I/O Level 3; 2 Kv power
RF conducted interference	EN 61000-4-6	Level 3; 10 V/rms 150 KHz - 80 MHz

Emissions to EN 50081-2

RF interference	EN 55011	Enclosure class A Power mains class A
-----------------	----------	--

Notes:

1. *Metal bezel of unit connected with ground lead from rear bezel screw to metal mounting panel.*

2. *Self-recoverable loss of performance during EMI disturbance at 10 V/m:
Process input and/or analog output signal may vary during EMI disturbance.*

For operation without loss of performance:

Unit is mounted in a metal enclosure (Buckeye SM7013-0 or equivalent)

I/O and power cables are routed in metal conduit connected to earth ground.

Refer to the EMC Installation Guidelines for additional information.

21. **CONSTRUCTION:** Die-cast metal front bezel that meets NEMA 4/IP65 requirements for wash-down and/or dusty environments when properly installed. Pollution Degree 2. Case body is black, high impact plastic (panel gasket and mounting clips included).

22. **CONNECTION:** Removable terminal blocks

23. **WEIGHT:** 1.2 lbs. (0.54 kg)

APPENDIX “C” - TROUBLESHOOTING GUIDE

The majority of all problems with the indicator can be traced to improper connections or improper programming set-ups. Be sure all connections are clean and tight and check the programming set-ups for correct data. For further technical assistance, contact technical support at the appropriate company numbers listed.

PROBLEM	POSSIBLE CAUSE	REMEDIES
NO DISPLAY	1. Power off, improperly connected, or brown-out.	1a. Check wiring. b. Verify power.
“PPPPPP” IN DISPLAY	1. Program data error.	1. Press “P” and Check data set-ups.
FLASHING DISPLAY	1. Totalizer overflow.	1. Reset totalizer.
“.....” IN DISPLAY	1. Loss of data set-ups.	1a. Check data set-ups. b. Check for electrical disturbance. c. Disconnect and reconnect power.
DISPLAY WANDERS	1. Loss of data set-ups.	1a. Check data set-ups. b. Disconnect and reconnect power. c. Check for electrical disturbance.
JITTERY DISPLAY	1. Electrical “Noise” in process or signal lines. 2. Process inherently unstable.	1a. Increase digital filtering. b. Increase display rounding increment. c. Re-route signal wires. 2. Dampen process to eliminate oscillations.
“ULULUL” IN DISPLAY	1. Probe unconnected 2. Broken or burnout probe. 3. Excessive probe temperature. 4. Input overload.	1. Connect probe. 2. Repair or obtain new probe. 3. Reduce temperature. 4. Check input levels.
“OLOLOL” IN DISPLAY	1. Input Underload (negative overload).	1. Check input levels.
“SHort” IN DISPLAY	1. Shorted probe.	1. Check probe.

APPENDIX “D” - PROGRAMMABLE FUNCTIONS

Programming of the indicator is divided into modular steps. Each module is a short sequence of data entries. The front panel buttons “UP” and “DOWN” (shown as “arrows” on the front panel) are used to change the data and set-ups, while the “P” button is used to *save* or *enter* the data. After pressing “P”, which gains entry into the programming mode, the programming modules are identified by the message “Pro” and a number in the display. “UP” and “DOWN” are used to select the desired programming module and “P” is used to enter it. All of the subsequent programming steps follow the same procedure. The rear terminal labeled “PGM. DIS.” must be ungrounded to gain access to programming. The following table lists the programming steps.

“Pro 0” - RETURN TO MEASUREMENT MODE

“Pro 1” - PROGRAM THERMISTOR TYPE, TEMPERATURE SCALE AND DECIMAL POINT POSITION

- “tYPE” - Select thermistor type (400/700)
- “SCALE” - Enter either degree (F or C)
- “dECPNT” - Enter resolution (0 or 0.0)

“Pro 2” - PROGRAM TEMPERATURE SLOPE AND OFFSET

- “SLOPE” - Enter display slope (0.0001 to 9.9999)
- “OFFSET” - Enter offset (-999 to 9999)

“Pro 3” - PROGRAM FUNCTIONS ACCESSIBLE WITH FRONT PANEL LOCKOUT ENGAGED

- “dSP AL” - Enable display alarms
- “ENT AL” - Enable enter alarms †
- “dSPHYS” - Enable display hysteresis
- “ENTHYS” - Enable enter hysteresis †
- “rSt AL” - Enable reset latched alarms
- “dSPbUF” - Enable display of peak/valley readings
- “rStbUF” - Enable reset of peak/valley readings†
- “SELdSP” - Enable switching display between input and total
- “rSttOt” - Enable reset total
- “dSPOFF” - Enable display offset value
- “ENTOFF” - Enable enter offset value †

“Pro 4” - PROGRAM DIGITAL FILTERING AND REMOTE INPUT FUNCTION

- “FILter” - Enter level of digital filtering
 - 0 - no digital filtering
 - 1 - normal filtering
 - 2 - increased filtering
 - 3 - maximum filtering
- “E1-CON” - Enter function of remote input
 - 0 - offset input to zero
 - 1 - reset total
 - 2 - reset and gate totalizer
 - 3 - gate totalizer
 - 4 - display hold
 - 5 - reset peak/valley
 - 6 - reset peak and start peak indicator
 - 7 - reset valley and start valley indicator
 - 8 - reset latched alarms
 - 9 - reset all alarms
 - 10 - toggle display between input and total
 - 11 - offset input to zero and totalizer the offset values
 - 12 - display hold with tare
 - 13 - instrument reading with synchronization
 - 14 - print request
- “E2-CON” - same functions as E1-CON

† This sequence may be subject to being locked-out due to other programmed sequences.

APPENDIX “D” - PROGRAMMABLE FUNCTIONS (Cont’d)

“Pro 5” - PROGRAM INTEGRATOR/TOTALIZER

- “dECPnt” - Enter decimal point for totalizer
- “tbASE” - Enter time base
 - 0 - second
 - 1 - minute
 - 2 - hour
- “SCLFAC” - Enter multiplying scale factor
- “Lo-cut” - Enter low-signal cut out

“Pro 6” - PROGRAM ALARMS

- “trAc” - Enable alarm value tracking
- “dISp” - Enable display alarm annunciators
- “LATC-1” - Enable alarm #1 latching
- “ASN-1” - Enter alarm #1 trigger source (temp. or integrator/ total)
- “AL-1” - Enter alarm #1 value
- “HYS-1” - Enter hysteresis value for alarm #1
- “Act-1” - Enter alarm #1 action (high or low)
- “LATC-2” - Enable alarm #2 latching
- “ASN-2” - Enter alarm #2 trigger source (temp. or integrator/ total)
- “AL-2” - Enter alarm #2 value
- “HYS-2” - Enter hysteresis value for alarm #2
- “Act-2” - Enter alarm #2 action (high or low)

“Pro 7” - PROGRAM SERIAL COMMUNICATIONS

- “bAud” - Enter baud rate
- “AddrES” - Enter loop address number (0-99)
- “Print” - Enter print function, or “P” command function through Serial Option
 - 0 - temp.
 - 1 - temp., peak/valley, and offset
 - 2 - temp. and alarms
 - 3 - temp, peak/valley, alarms, hysteresis, and offset
 - 4 - total
 - 5 - temp. and total
 - 6 - temp., total, peak/valley, and offset
 - 7 - total and alarms
 - 8 - temp., total and alarms
 - 9 - temp., total, peak/valley, alarms, hysteresis, and offset
- “FULL” - Enable complete or abbreviated printing

“Pro 8” - PROGRAM RE-TRANSMITTED ANALOG OUTPUT

- “ASIN” - Select source of analog output (input or total)
- “AN-Lo” - Enter 4 mA or 0 VDC display value
- “AN-HI” - Enter 20 mA or 10 VDC display value

“Pro 9” - SERVICE OPERATIONS (Protected by access codes)

- “Code 39” - Serial hardware (loop-back) test
- “Code 48” - Basic input calibration
- “Code 66” - Reset programming to factory configuration

APPENDIX “E” - ORDERING INFORMATION

MODEL NO.	DESCRIPTION	TOTALIZER/ PEAK/VALLEY SLOPE/OFFSET E2-CON	ALARM OUTPUT	SERIAL OUTPUT	ANALOG OUTPUT	PART NUMBERS FOR AVAILABLE SUPPLY VOLTAGES
						115/230 VAC
IMY	Intelligent Meter for Thermistor Inputs	NO	NO	NO	NO	IMY00160
		NO	YES	NO	NO	IMY00162
		YES	NO	NO	NO	IMY02160
		YES	NO	YES	NO	IMY02161
		YES	YES	NO	NO	IMY02162
		YES	NO	NO	4 to 20 mA	IMY02163
		YES	YES	YES	4 to 20 mA	IMY02167
		YES	YES	YES	0 to 10 VDC	IMY02169

For information on Pricing, Enclosures & Panel Mount Kits refer to the RLC Catalog or contact your local RLC distributor.

LIMITED WARRANTY

The Company warrants the products it manufactures against defects in materials and workmanship for a period limited to one year from the date of shipment, provided the products have been stored, handled, installed, and used under proper conditions. The Company's liability under this limited warranty shall extend only to the repair or replacement of a defective product, at The Company's option. The Company disclaims all liability for any affirmation, promise or representation with respect to the products.

The customer agrees to hold Red Lion Controls harmless from, defend, and indemnify RLC against damages, claims, and expenses arising out of subsequent sales of RLC products or products containing components manufactured by RLC and based upon personal injuries, deaths, property damage, lost profits, and other matters which Buyer, its employees, or sub-contractors are or may be to any extent liable, including without limitation penalties imposed by the Consumer Product Safety Act (P.L. 92-573) and liability imposed upon any person pursuant to the Magnuson-Moss Warranty Act (P.L. 93-637), as now in effect or as amended hereafter.

No warranties expressed or implied are created with respect to The Company's products except those expressly contained herein. The Customer acknowledges the disclaimers and limitations contained and relies on no other warranties or affirmations.

Red Lion Controls
20 Willow Springs Circle
York PA 17402
Tel +1 (717) 767-6511
Fax +1 (717) 764-0839

Red Lion Controls France
56 Boulevard du Courcerin, Batiment 21,
ZI Pariest F-77183 Croissy Beaubourg
Tel +33 (64) 80 12 12
Fax +33 (64) 80 12 13

Red Lion Controls BV
Databankweg 6C
NL - 3821 AL Amersfoort
Tel +31 (33) 472 32 25
Fax +31 (33) 489 37 93